

## Universal and Dimmable LED Driver

### Features

- Input voltage range from 5V to 450V
- Cascode topology for lower switching loss and surge voltage
- Constant off time control
- Line compensation of output current
- Enable pin
- Switch/PWM/Linear dimming function
- Leading-edge blanking
- Frequency modulation in short circuit protection and low output voltage condition
- Over-temperature protection
- Over-current protection
- SOP-8 package, with few external components needed

### Application

- DC/DC or AC/DC LED driver application
- LED T-bar lighting
- Cabin light in car
- Both non-isolation and isolation lighting in high input voltage

### General Description

The GR8210 is a high brightness LED driver with the cascode topology that patented by Greenergy. A high voltage power NMOSFET,  $BV_{DSS}$  is 600V, as the high side device and the power NMOSFET inside the GR8210 as the low side device in this cascode topology. A Zener voltage, was generated by ST pin of the GR8210, turn on the high side device all the time by connected to the gate terminal of the high side device. The source terminal and the drain terminal of the high side device are connected to the DRN pin of the GR8210 and the input voltage rail respectively to absorb the very large voltage potential. The current peak value was decided by the sensing resistor in the CS pin, the low side device was turned off by the current peak detection then delay a fixed off time that set by the resistor in the RT pin of GR8210.

There are PWM and liner dimming in GR8210 to adjust the LED brightness. In the abnormal operation, the inner OTP function could protect the IC damage.

\* Refer to Feature List on page 2 for the switching dimming function

### Ordering and Marking Information

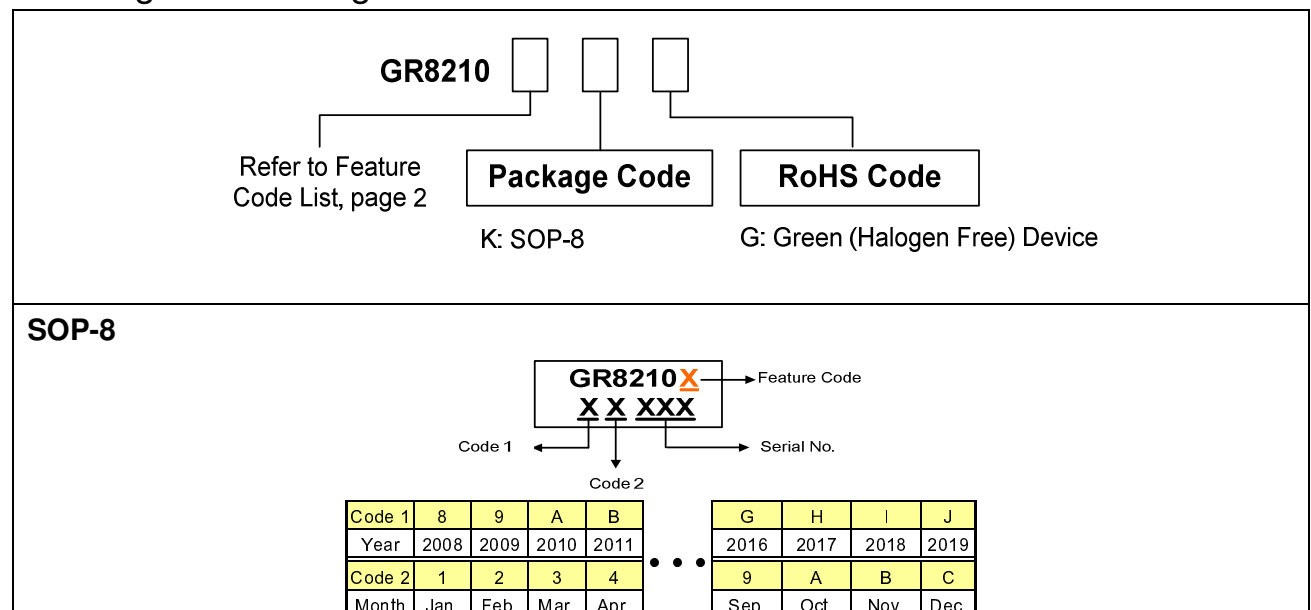

Greenergy OPTO Inc. reserves the right to make changes to improve reliability or manufacture ability without notice, and advise customers to obtain the latest version of relevant information to verify before placing orders.

## Feature Code List

Part Name	Switching Dimming
<b>GR8210N</b>	No
<b>GR8210D</b>	Yes

## Pin Configuration

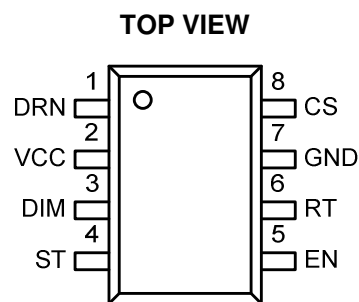

## Pin Description

Pin No.	Name	Function
1	DRN	The drain terminal of the internal NMOSFET
2	VCC	The output of the internal regulator
3	DIM	The dimming signal input pin
4	ST	The anode terminal of the internal Zener diode
5	EN	The enable input terminal
6	RT	An external resistor located from this pin to GND to generate a reference current to fix the off time in the switching operation.
7	GND	Ground of the circuit
8	CS	Current sense voltage input terminal, the LED current also flows from this pin to the sense resistor outside

### Absolute Maximum Ratings

Supply voltage, $V_{CC}$	-----	5.5V
Drain voltage, $V_{DRN}$	-----	26V
DIM voltage to GND, $V_{DIM}$	-----	-0.3V ~ 6V
Zener voltage, $V_{ST}$	-----	18V
EN voltage to GND, $V_{EN}$	-----	-0.3V ~ 6V
RT voltage to GND, $V_{RT}$	-----	-0.3V ~ 6V
CS voltage to GND, $V_{CS}$	-----	-0.3V ~ 6V
Junction temperature	-----	150°C
Operating ambient temperature	-----	-20°C ~ 85°C
Storage temperature range	-----	-65°C ~ 150°C
Package thermal resistance (SOP-8), $\theta_{JA}$	-----	160°C/W
Power dissipation (SOP-8, at ambient temperature = 85°C)	-----	400mW
Lead temperature (Soldering, 10sec)	-----	260°C

### Recommended Operating Conditions

Item	Min.	Max.	Unit
Input voltage, $V_{IN}^*$	5	450	V
Output current, $I_{OUT}^*$	0.1	0.8	A

\* Refer to the Figure-1.

Block Diagram

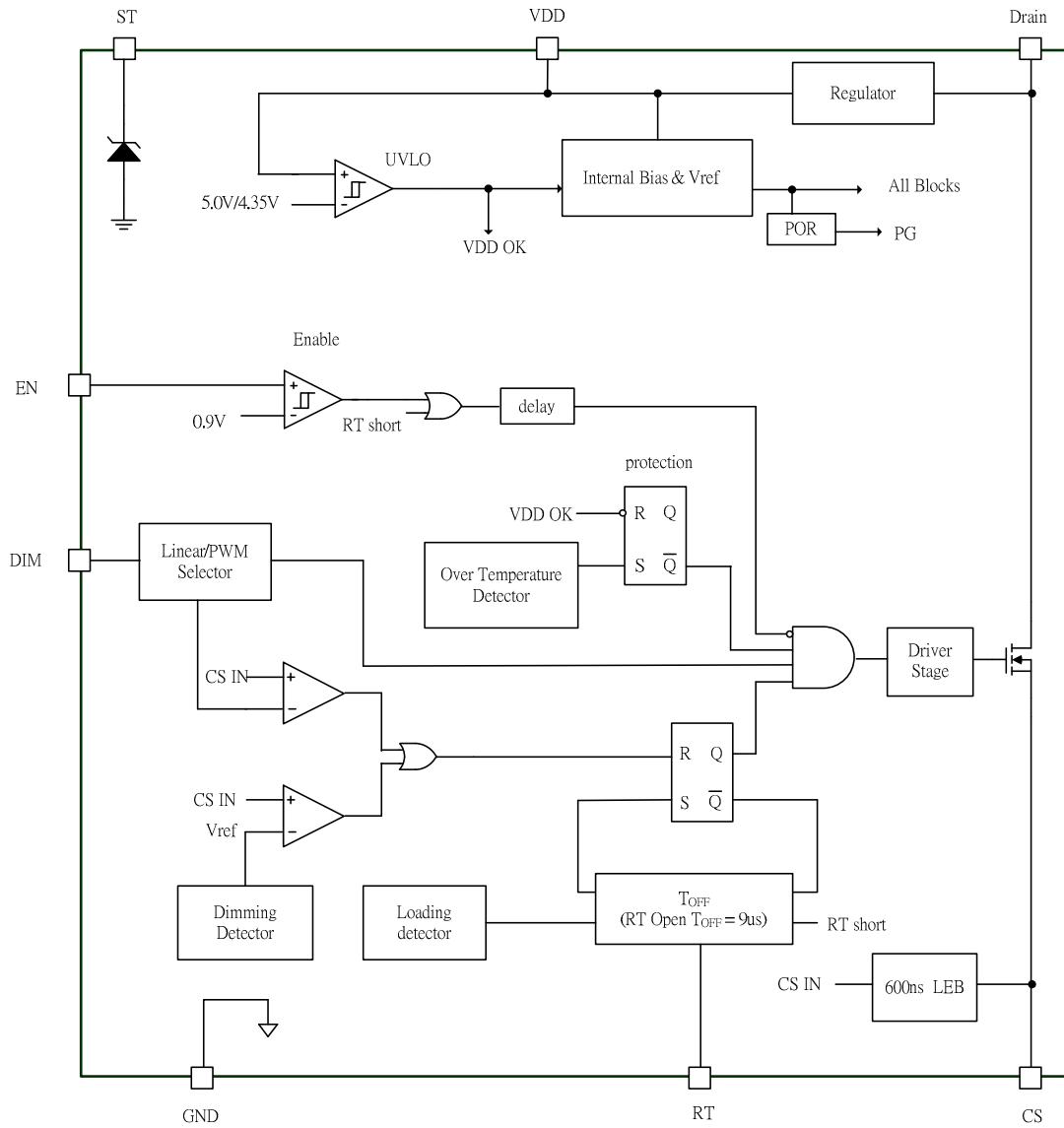

**Electrical Characteristics** ( $V_{CC} = 5V$ ,  $T_A = 25^\circ C$ , unless otherwise specified.)

Parameter	Symbol	Conditions	Min.	Typ.	Max.	Unit
-----------	--------	------------	------	------	------	------

**INPUT VOLTAGE**

Input voltage range	$V_{IN}$	With Cascode NMOSFET	5	-	450	V
---------------------	----------	----------------------	---	---	-----	---

**VCC SECTION**

$V_{CC}$ UVLO	$V_{UVLO}$		4.8	5.0	5.2	V
$V_{CC}$ UVLO hysteresis	$V_{UV\_LOHY}$			0.65		V
Operation current	$I_{Q-OP}$	Normal Operation	0.3	0.5	0.9	mA

**ST SECTION**

Start up voltage in normal operation	$V_{ST}$	$I_{ST} = 50\mu A$	12	15	18	V
Start up current at 156V	$I_{ST}$	$V_{IN} = 156V$ , $R_{ST} = 2M\Omega$	50	70.5	90	$\mu A$

**CURRENT SENSE SECTION**

Peak current reference voltage	$V_{CS1}$	$V_{IN} = 312V$ , $L = 4.7\mu H$ , $R_{LOAD} = 10\Omega$ , $R_{CS} = 0.3\Omega$ , asynchronous rectifier: xxxx.	240	250	260	mV
Leading edge blanking time	$T_{LEB}$		500	600	700	ns

**INTERNAL POWER NMOSFET SECTION**

Turned on resistance	$R_{DS(ON)}$	$V_{CC} = 5V$ , $V_{CS} = 0.1V$ , $R_{DRN} = 10K\Omega$ from $V_{IN}$ to DRN	0.3	0.7	1.0	$\Omega$
----------------------	--------------	--	-----	-----	-----	----------

**EN SECTION**

Enable threshold	$V_{EN}$		0.85	0.9	0.95	V
Enable function hysteresis	$V_{EN\_HYS}$			0.1		V
Delay cycles of enable pin	$T_{EN\_D}$			32		Cycles

**RT SECTION**

RT threshold voltage	$V_{RT}$	$V_{CC} = 5V$ , $R_{RT} = 200K\Omega$	1.14	1.2	1.26	V
Constant off time	$T_{OFF}$	$V_{CC} = 5V$ , $R_{RT} = 200K\Omega$	20.5	22.5	24.5	$\mu s$
Constant off time	$T_{OFF\_default}$	$V_{CC} = 5V$ , RT to $V_{CC}$	9	10	11	$\mu s$

**DIMMING FUNCTION (LD/PD)**

PWM dimming input low voltage threshold	$V_{OL}$		-	-	0.9	V
PWM dimming input high voltage threshold	$V_{OH}$		2	-	-	V
Linear dimming voltage threshold of 100% current regulation	$V_{L\_MAX}$	100% Output Current.	0.475	0.5	0.525	V

**Electrical Characteristics (Cont.)**

<b>Parameter</b>	<b>Symbol</b>	<b>Test Conditions</b>	<b>Min</b>	<b>Typ</b>	<b>Max</b>	<b>Units</b>
------------------	---------------	------------------------	------------	------------	------------	--------------

**OVER TEMPERATURE PROTECTION SECTION**

OTP trip level	T <sub>OTP</sub>			150		°C
OTP hysteresis	T <sub>OTP_HYS</sub>			25		°C

\* Switching dimming is optional.



### Peak Current Detection and Line Voltage Compensation

In the Figure-3, a current flow through  $M_2$  and  $R_S$  during the  $M_2$  on period. This current caused the  $V_{CS}$  increasing, the comparator pass the peak current information to the control circuit to turn off  $M_2$  while  $V_{CS}$  reach to 0.25V. The peak,  $I_{PK}$ , current could determine by (1):

$$I_{PK} = \frac{0.25}{R_S} \quad (1)$$

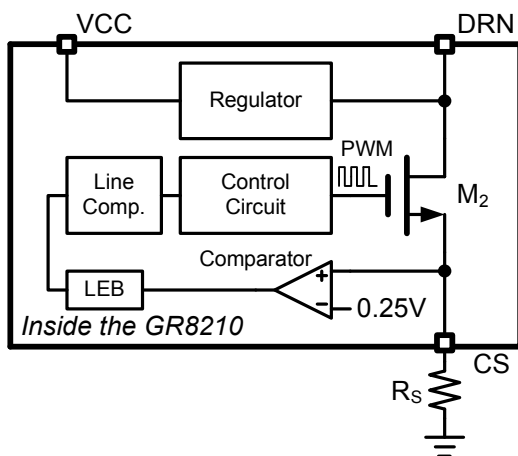

Figure-3 The brief schematic to explain the peak current detection and line voltage compensation.

In the Figure-4, there are large voltage spike in the turn on edge of  $V_{P1}$  to  $V_{P3}$ . These voltage spikes probably affect the wrong peak current detection. To prevent this fault, a LEB block applied in the GR8210 to generate a fixed period to blank the voltage spike in the CS.

The  $T_{pg}$  in the Figure-4 is the propagation delay of  $M_2$  turned off. The  $T_{pg}$  was defined from the  $V_{CS}$  reaching 0.25V to  $M_2$  turned off. In the  $T_{pg}$  period, the  $V_{CS}$  still ramps up from 0.25V due to the  $M_2$  was not turned off yet. For that reason, the end of  $V_{CS}$  in the higher  $V_{IN}$  is greater than the end of  $V_{CS}$  in the lower  $V_{IN}$ .

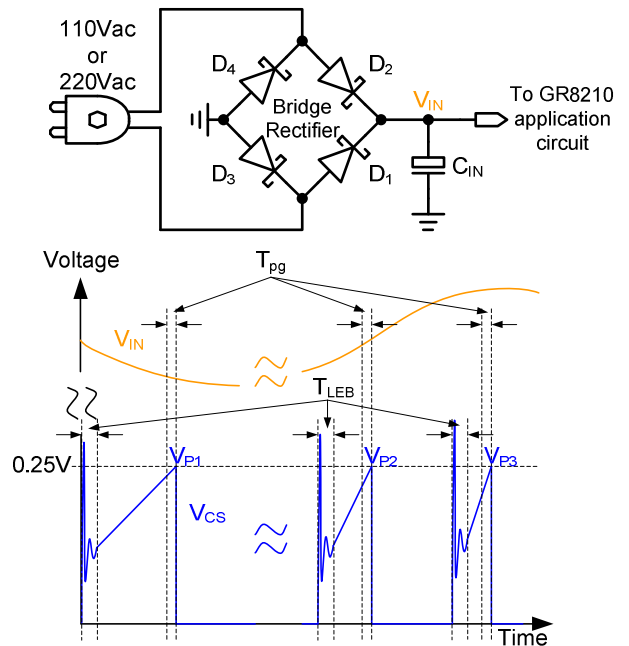

Figure-4 The waveforms of  $V_{IN}$  and  $V_{CS}$  to explain the operation of  $T_{LEB}$  and line voltage compensation. The sketch map explains the generation of  $V_{IN}$  and the line voltage change of  $V_{IN}$  due to the limited  $C_{IN}$ .

The different height of  $V_{CS}$  means the different  $I_{OUT}$  that shown in the Figure-1. The line voltage compensation function was applied in the GR8210 to improve the output current regulation. The  $V_{P1}$  to  $V_{P3}$  in the Figure-4 illustrates the compensation results by the line voltage compensation.

### OFF Time Setting

GR8210 operates with the peak current sensing and the constant off time. The peak current sensing and the line voltage compensation align the peaks of  $V_{CS}$  identically to determine the same  $I_{PEAK}$  that shown in the Figure-5. The  $I_{VALLEY}$  was determined by the  $T_{OFF}$ . GR8210 provides an off time setting function via connect a resistor from RT to GND. A simple way is connect RT to VCC directly to use the default off time that the value is approximately 9.3μs.

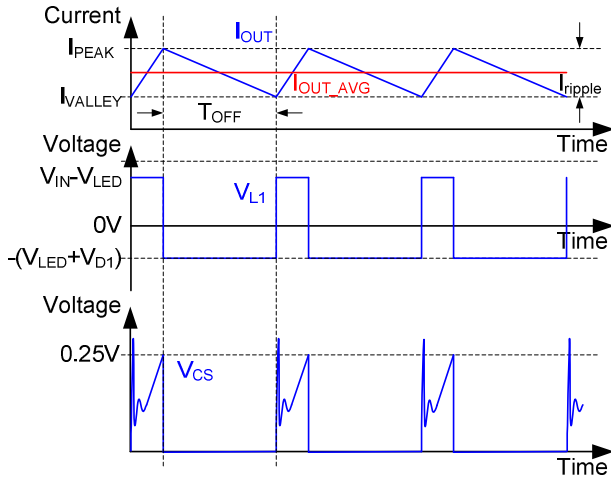

Figure-5 The waveforms of  $V_{CS}$ ,  $V_{L1}$  and  $I_{OUT}$  that shown in the Figure-1.

### Inductor Selection and Output Current Setting

The (2) and (3) were generated according to the Figure-5. They usually used to determine the inductance of the power inductor.

$$I_{ripple} = I_{OUT} \cdot K \quad (2)$$

$$L = \frac{(V_{LED} + V_{D1})}{I_{ripple}} \cdot T_{OFF} \quad (3)$$

Where, the  $I_{OUT}$  is output current that user defined, the  $K$ . is the percentage of  $I_{OUT}$  to estimate the worse case and the value usually is range of 20%~40%. Beside, the maximum rate current and saturation current of the inductor must greater than the  $I_{PEAK}$  that shown in the Figure-5.

### $R_s$ Selection

Base on the decision of  $L$ , we can calculate the  $R_s$  by (4).

$$R_s = \frac{0.5}{(2 + K) \cdot I_{OUT}} \quad (4)$$

### Input Capacitor Selection

In the Figure-1, the  $C_{IN}$  retained the  $V_{IN}$  with ac part, the waveform was shown as Figure-6. Before the input capacitance decision, the users must define the input voltage ripple in the system. A useful rule

can find the valley voltage of the input voltage, add 5volts with the summation of the LED forward voltage and let the input valley voltage higher than this value.

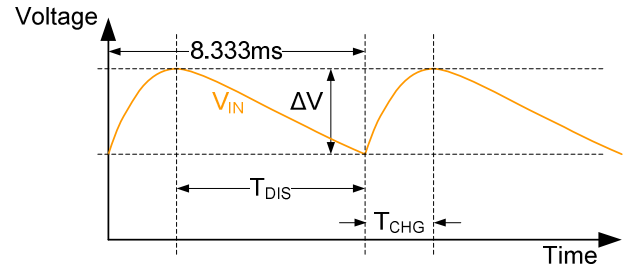

Figure-6 The waveform of input voltage in the  $C_{IN}$ .

The (5) to (7) could be used to estimate the capacitance of  $C_{IN}$  that shown in the Figure-1.

$$T_{CHG} = \frac{8.333m}{2} \cdot \left[ 1 - \frac{\sin^{-1}\left(1 - \frac{\Delta V}{V_{IN}}\right)}{90} \right] \quad (5)$$

$$T_{DIS} = 8.333m - T_{CHG} \quad (6)$$

$$C_{IN} = \frac{0.5 \cdot I_{OUT} \cdot T_{DIS}}{\Delta V} \quad (7)$$

Note that, the  $\Delta V$  is the input voltage ripple that defined by the users, the  $T_{CHG}$  is the charging period and the  $T_{DIS}$  is the discharging period. In the other considerations, the maximum rate voltage of the  $C_{IN}$  must be greater than the peak value of  $V_{IN}$ , the maximum RMS current of  $C_{IN}$  must be greater than half  $I_{OUT}$ .

### Freewheel Diode Selection

Two specifications of freewheel diode must be considered, the maximum reverse voltage must be greater than maximum voltage across the diode. The average rectified current also must be greater than  $I_{PEAK}$  that shown in the Figure-5. The ultra fast diode is recommended to use as the freewheel diode.

### External NMOSFET Selection

The external NMOSFET in the Figure-1,  $M_1$ , was connected to the DRN of the GR8210. Most of the input voltage was across the drain and source terminals of  $M_1$ . The specifications of a suitable device are, the continuous current range of 1A to 2A, the maximum drain to source voltage is 600V and the maximum gate to source voltage is 20V. To choose an external NMOSFET with better specifications than above will not be improve the efficiency significantly.

### Zener Diode Selection

Users can select an external Zener diode to provide the gate voltage for the external NMOSFET. The range of the Zener voltage is 12V to 15V.

### PWM Dimming Operation

The users could apply a digital duty modulation signal into DIM pin to use the PWM dimming. The  $I_{OUT}$ , shown in the Figure-1, would regulate in the high state of PWM signal and stop regulating in the low state of PWM signal.

### Linear Dimming Operation

An analog dimming function was also applied in the GR8210. The users could apply an analog voltage that range from 0V to 0.5V into DIM pin to adjust the LED brightness. The DIM pin was a multi-function input. The GR8210 detects which dimming manner was applied after power on procedure. Therefore, the GR8210 can not alternate between PWM dimming and linear dimming during the operation.

### Switching Dimming Operation

The GR8210 gives a very convenient switching dimming function for users without extra components and control signal input. The users could turn off the input power, shown as the  $V_{IN}$  in the Figure-7, right after that turn on the power again

during 1.5sec to dimming the brightness by the power switch. There are four current levels in the switching dimming operation. The level\_1 to level\_4 are determined by the  $V_{CS\_SW1}$  to  $V_{CS\_SW4}$  respectively.

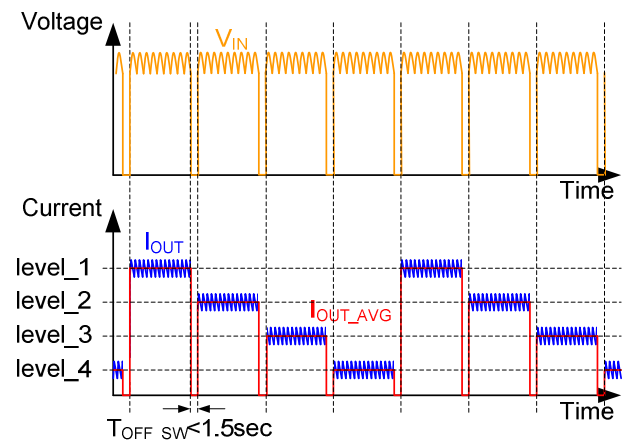

Figure-7 The waveforms of  $V_{IN}$ ,  $I_{OUT}$  an  $I_{OUT\_AVG}$  that shown in Figure-1. These waveforms illustrate the switching dimming procedure and behavior.

### EN Function (Brown IN/OUT Operation)

The EN pin provides a control function to the users. The users can turn off the operation by apply a TTL logic signal via the EN pin.

Beside, EN pin can also used as a Brown IN/OUT function to make sure the operation under the suitable input voltage. In the lower input voltage, the GR8210 could stop operation via the brown in detection. The GR8210 detects the input voltage information by a voltage divider as shown in the Figure-8.

$$R_{BRN2} = \frac{0.9}{I_{BRN}} \quad (8)$$

$$R_{BRN1} = \frac{V_{IN\_BRN} \cdot R_{BRN2}}{0.9} - R_{BRN2} \quad (9)$$

(8) and (9) can be used to estimate the resistance of the  $R_{BRN1}$  and  $R_{BRN2}$ . Note that, the  $I_{BRN}$  is the acceptable current by the users, the  $V_{IN\_BRN}$  is the brown in voltage threshold set by the users.

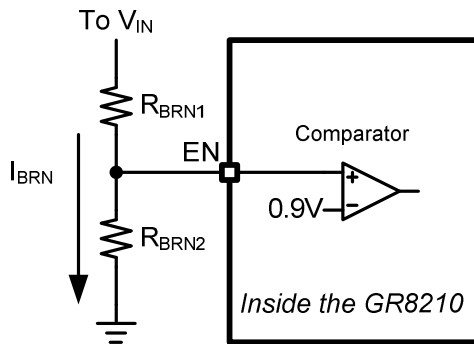

Figure-8 The sketch map of Brown In/Out setting.

### Over Temperature Protection (OTP)

The GR8210 provides an inner over temperature protection function to prevent the system damage. In some abnormal situation, a high temperature could trip the OTP to latch off the GR8210. The users should power on again to reset this latch.

### Short Circuit Protection

In the Figure-9, the  $I_{OUT}$  runs away due to the  $I_{VALLEY}$  always higher than  $I_{PEAK}$  in the short circuit conditions. To prevent this situation, the GR8210 could increase the  $T_{OFF}$  by product a multiplier to control the  $I_{VALLEY}$  stay below  $I_{PEAK}$ . The multiplier might be 2, 4 and 8 that decided by the GR8210 control scheme.

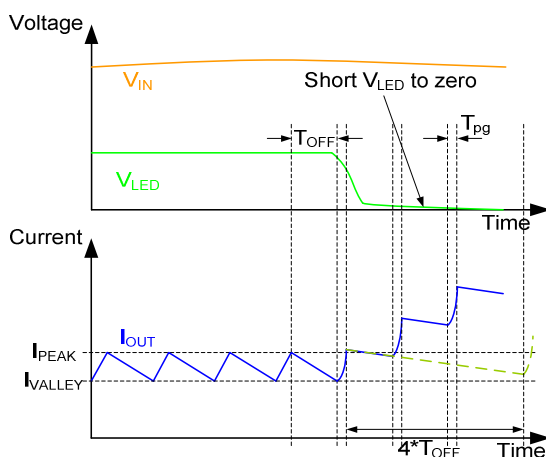
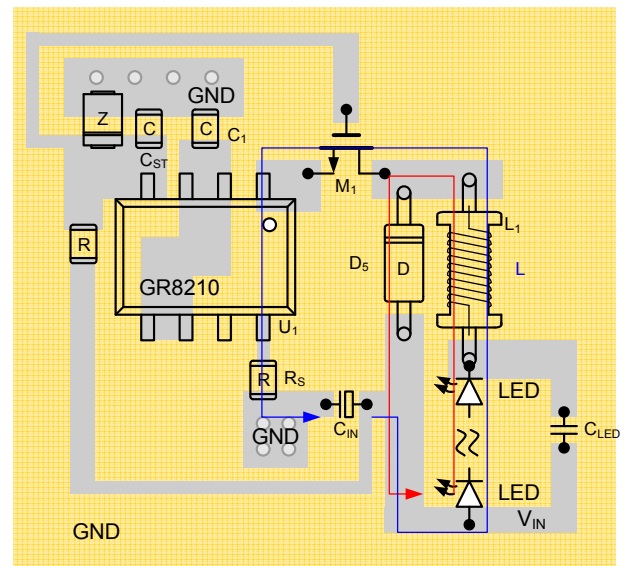

Figure-9 The sketch waveforms to illustrate the short circuits protection.

### PCB Layout Consideration

Figure-10 shows the PCB layout considerations of GR8210. These guidelines detailed below.

- (1) Locate the  $U_1$ ,  $R_S$ ,  $C_{IN}$ ,  $D_5$ ,  $L_1$  and  $M_1$  closely each other to reduce the current loop of on period and off period.
- (2) Locate the  $R_S$ ,  $C_1$  and  $C_{ST}$  close to the GR8210 as possibly.
- (3) Locate the  $M_1$  to the GR8210 close as possibly to reduce the distance between the source terminal of  $M_1$  and pin1 of  $U_1$ .



- Top Layer    ■ Bottom Layer
- ON Period Current Loop
- OFF Period Current Loop

Figure-10 The PCB layout sketch map shown the layout considerations and the relative locations of the key components.

**Typical Application Circuit**

Figure-11 110Vac or 220Vac input voltage, default off time, 24pcs LEDs light bar, 350mA application circuit.

**Package Information**

SYMBOL	SOP-8			
	MILLIMETERS		INCHES	
	MIN.	MAX.	MIN.	MAX.
A		1.75		0.069
A1	0.10	0.25	0.004	0.010
A2	1.25		0.049	
b	0.31	0.51	0.012	0.020
c	0.17	0.25	0.007	0.010
D	4.80	5.00	0.189	0.197
E	5.80	6.20	0.228	0.244
E1	3.80	4.00	0.150	0.157
e	1.27 BSC		0.050 BSC	
h	0.25	0.50	0.010	0.020
L	0.40	1.27	0.016	0.050
$\theta$	0°	8°	0°	8°

Note: 1. Followed from JEDEC MS-012 AA.

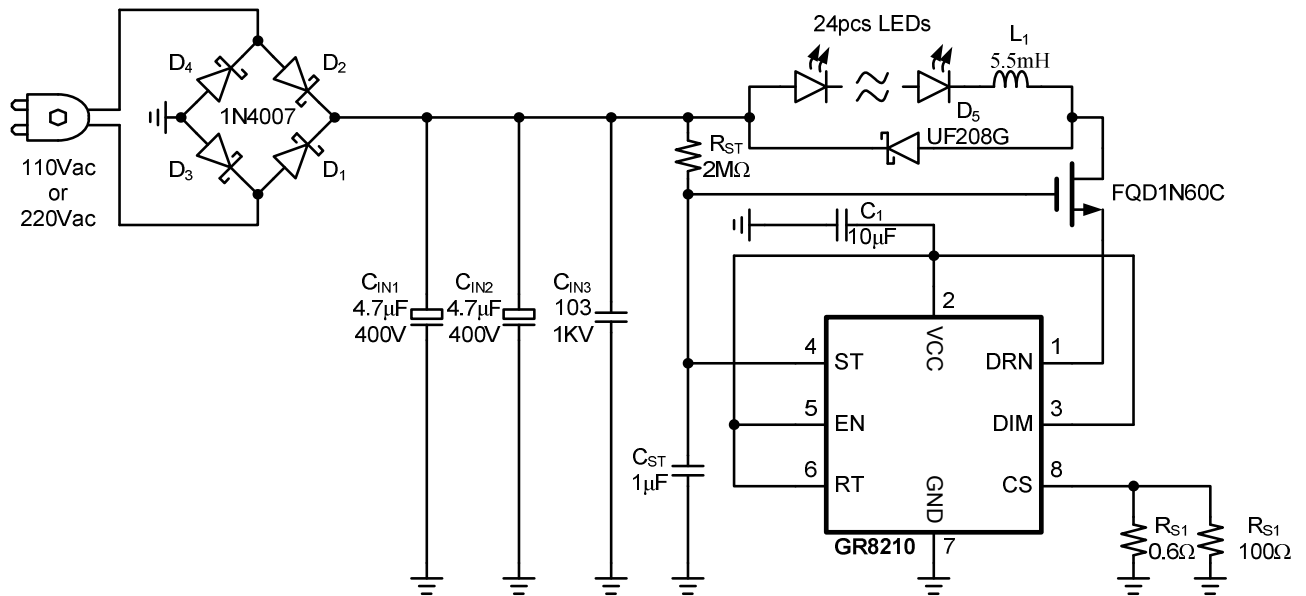
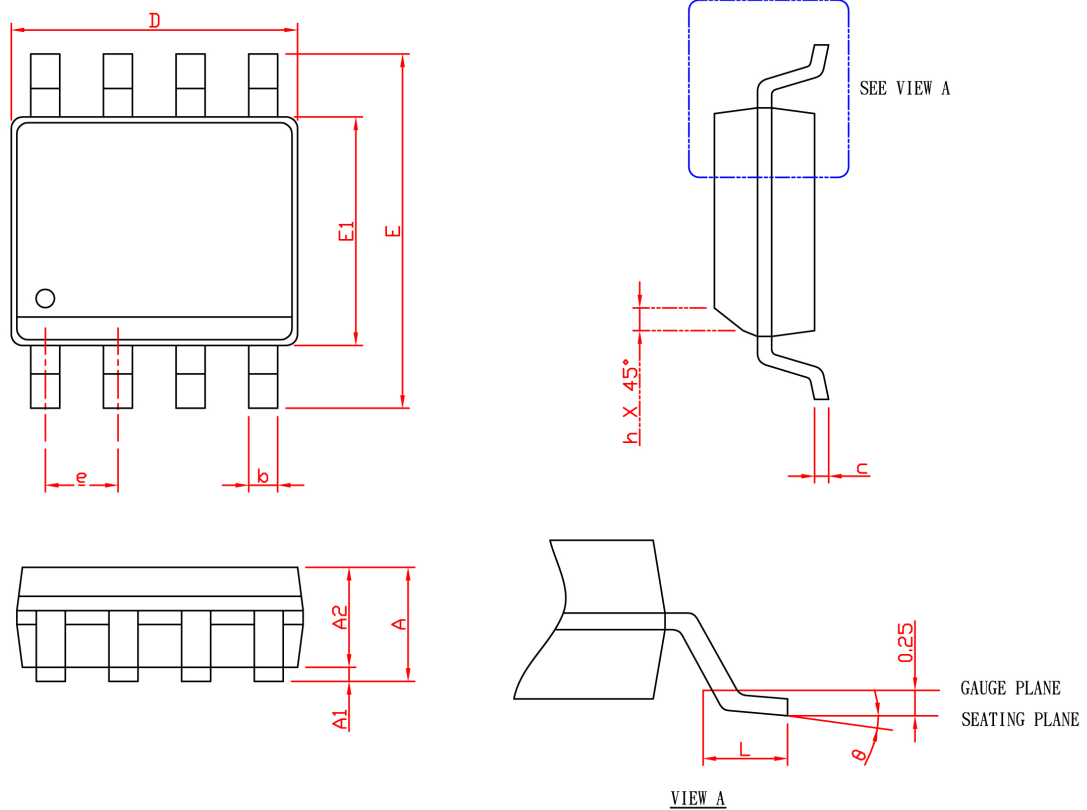
2. Dimension "D" does not include mold flash, protrusions or gate burrs. Mold flash, protrusion or gate burrs shall not exceed 6 mil per side.

3. Dimension "E1" does not include inter-lead flash or protrusions. Inter-lead flash and protrusions shall not exceed 10 mil per side.

## Carrier Tape & Reel Dimensions

### SOP-8

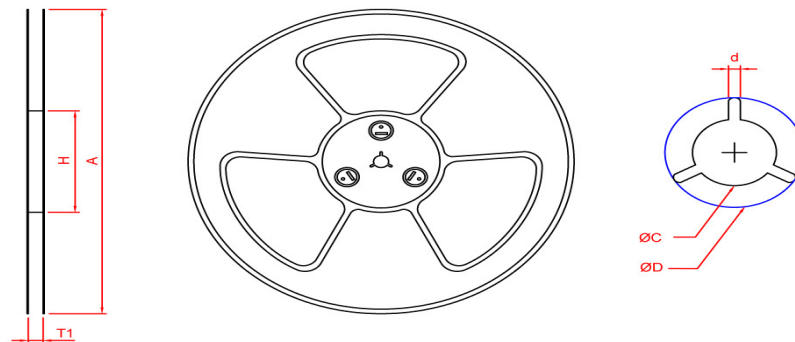
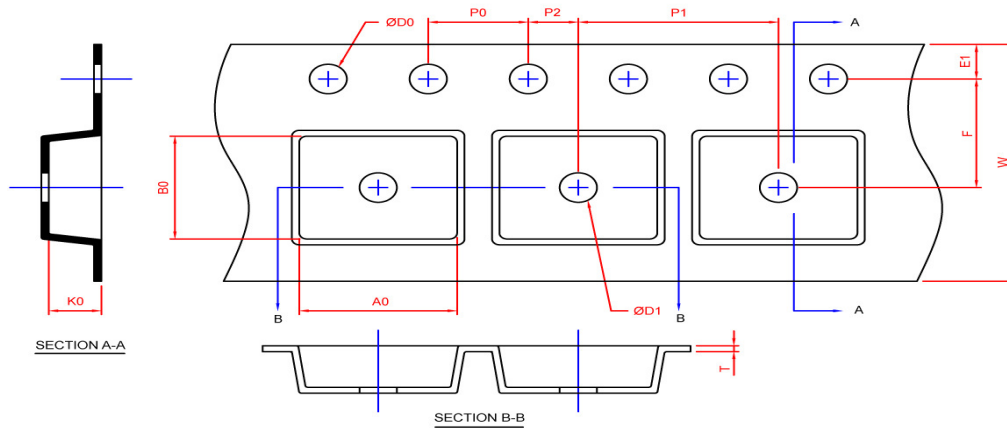

Application	A	H	T1	C	d	D	W	E1	F
SOP-8	$330.0 \pm 2.0$	50 MIN.	$12.4 + 2.00$ $-0.00$	$13.0 + 0.50$ $-0.20$	1.5 MIN.	20.2 MIN.	$12.0 \pm 0.30$	$1.75 \pm 0.10$	$5.5 \pm 0.05$
	P0	P1	P2	D0	D1	T	A0	B0	K0
	$4.0 \pm 0.10$	$8.0 \pm 0.10$	$2.0 \pm 0.05$	$1.5 + 0.10$ $-0.00$	1.5 MIN.	$0.6 + 0.00$ $-0.40$	$6.40 \pm 0.20$	$5.20 \pm 0.20$	$2.10 \pm 0.20$

(mm)

### Devices Per Unit

Application	Carrier Width	Cover Tape Width	Devices Per Reel
SOP-8	12	-	2500

Greenergy OPTO, Inc. reserves the right to make corrections, modifications, enhancements, improvements, and other changes to its products and services at any time and to discontinue any product or service without notice. Customers should obtain the latest relevant information before placing orders and should verify that such information is current and complete.