

Green-Mode PWM Controller with Integrated Protections

Features

- High-voltage (500V) startup circuit
- Standby 100mW solution
- Current mode PWM
- Very low startup current (<20uA)
- Under-voltage lockout (UVLO)
- Non-audible-noise green-mode control
- Programmable switching frequency
- Cycle-by-cycle peak current limiting
- Internal leading-edge blanking
- Internal slope compensation
- Internal 4ms soft start (Fs = 65KHz)
- Gate output voltage clamp
- Soft driving for reducing EMI
- Over-voltage protection (OVP) on Vcc pin
- Over-load protection (OLP)
- 500mA driving capability

Applications

- Open-frame SMPS
- Switching AC/DC adapter

Description

The GR8874 is a highly-integrated, low startup current, current mode PWM controller with green-mode function and high-voltage start up circuit. A high-voltage current source supplies the start up current and the traditional start-up resistor can be saved in order to reduce the power dissipation due to start-up resistor. The controller also includes the leading-edge blanking of the current sensing, internal slope compensation and cycle-by-cycle peak current limiting. It is also integrated soft driving for reducing EMI, gate output voltage clamp function for protecting power MOSFET. GR8874 provides several protections such as OLP, OVP, and OCP for fault conditions. The GR8874 improves the performance and reduces the cost of power supplies. It is available in both 8-pin SOP and 8-pin DIP package.

Ordering and Marking Information

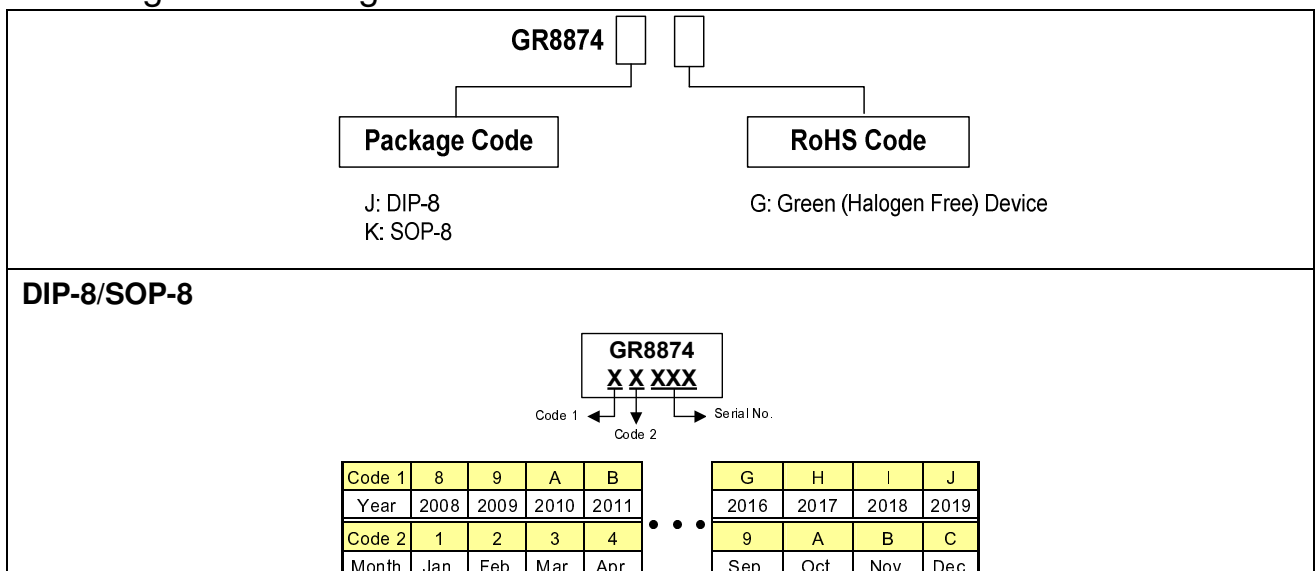

Greenergy OPTO Inc. reserves the right to make changes to improve reliability or manufacture ability without notice, and advise customers to obtain the latest version of relevant information to verify before placing orders.

Pin Configuration

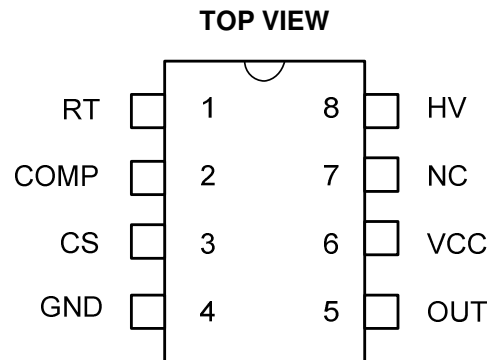

Pin Description

Pin	Symbol	Description
1	RT	Connecting a resistor to ground, this resistor determine the switching frequency
2	COMP	Voltage feedback pin, by connecting a photo-coupler to control the duty cycle
3	CS	Current sense pin, connect to sense the MOSFET current
4	GND	Ground
5	OUT	The output for driving the external MOSFET
6	VCC	Power supply pin
7	NC	Unconnected pin
8	HV	This pin is connected to positive terminal of bulk capacitor. It provides the startup current. When UVLO (on) is tripped, this HV loop will be off thus limit the power loss on the startup circuit.

Absolute Maximum Ratings

Supply voltage VCC	-----	35V
High-voltage pin, HV	-----	- 0.3 ~ 500V
COMP, RT, CS	-----	-0.3 ~ 7V
Junction temperature	-----	150°C
Operating ambient temperature	-----	-20°C ~ 85°C
Storage temperature range	-----	-65°C ~ 150°C
SOP-8 package thermal resistance	-----	160°C/W
DIP-8 package thermal resistance	-----	100°C/W
Power dissipation (SOP-8, at ambient temperature = 85°C)	-----	400 mW
Power dissipation (DIP-8, at ambient temperature = 85°C)	-----	650mW
Lead temperature (All Pb free packages, soldering, 10sec)	-----	260°C
ESD voltage protection, human body model	-----	2KV
ESD voltage protection, machine model	-----	200V

Recommended Operating Conditions

Item	Min.	Max.	Unit
Supply voltage VCC	11.5	25	V
Switching frequency	50	130	KHz
COMP pin capacitor	1	10	nF
Start-up capacitor	10	47	uF

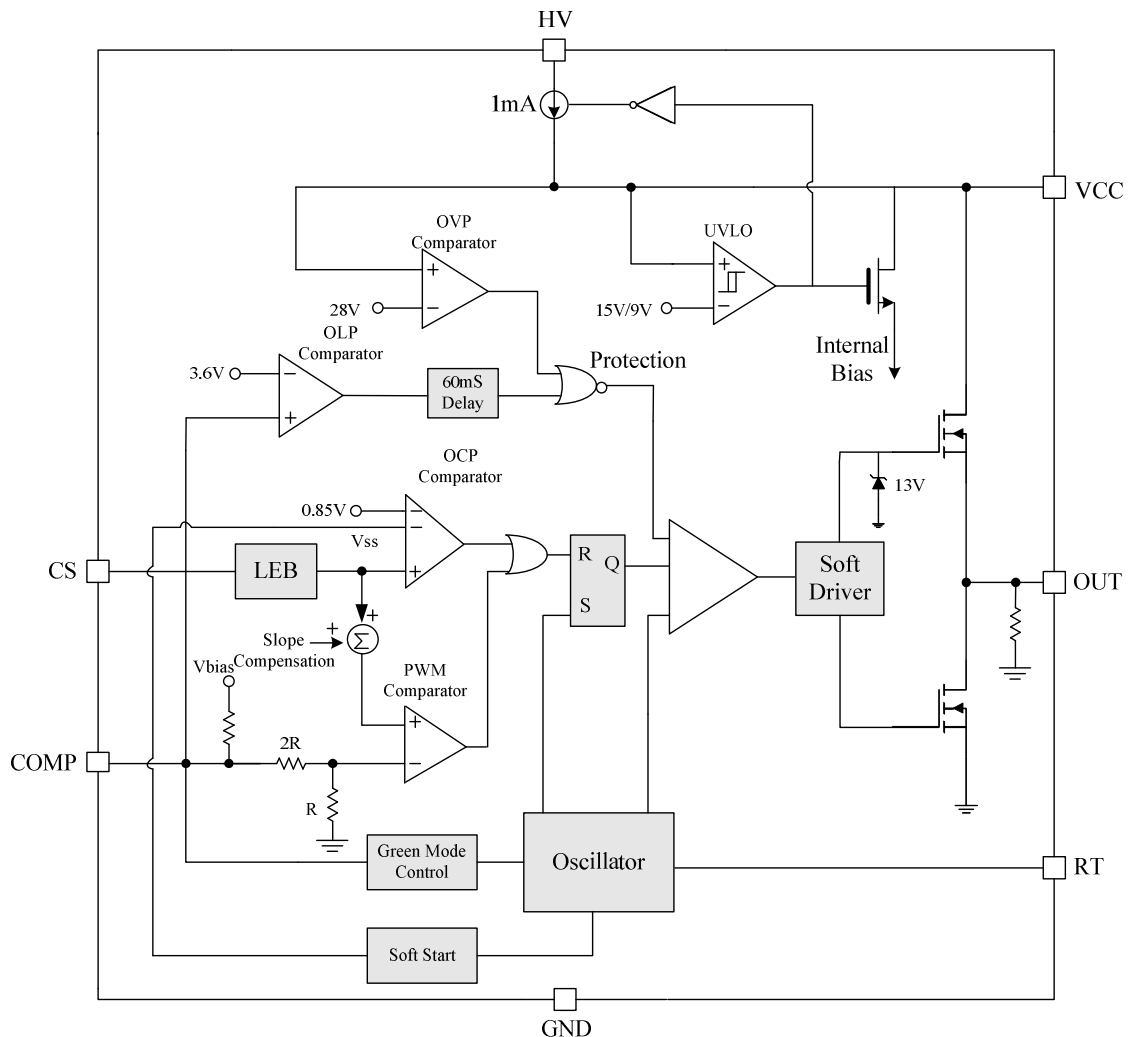
Block Diagram



Electrical Characteristics (TA = +25°C unless otherwise specified, VCC = 15.0V)

Parameter	Pin	Min.	Typ.	Max.	Unit
-----------	-----	------	------	------	------

HIGH-VOLTAGE SUPPLY (HV Pin)

High-voltage current source (Vcc = 0V)	8	0.5	1.0	1.55	mA
Off-state leakage current	8	0		25	uA

SUPPLY VOLTAGE

Startup current	6			20	uA
Operating current (with 1nF load on OUT pin), Vcomp = 0V	6		1.2		mA
Operating current (with 1nF load on OUT pin), Vcomp = 2.5V	6		2.2		mA
Operating current (with 1nF load on OUT pin), protection tripped (OLP, OVP)	6		0.8		mA
UVLO (on)	6	14	15	16	V
UVLO (off)	6	8.3	9.3	10.3	V
OVP level on VCC pin	6	26.5	28	29.5	V

VOLTAGE FEEDBACK

Short circuit current, Vcomp = 0V	2		1		mA
Open loop voltage, COMP pin open	2	4.6	5	5.4	V
Green mode threshold voltage	2		1.2		V

CURRENT SENSING

Maximum input voltage, Vcs (off)	3	0.80	0.85	0.90	V
Leading-edge blanking time	3	250	350	450	nS
Input impedance	3	1			MΩ
Delay to output	3		100		nS

OSCILLATOR

Frequency (RT = 100KΩ)	3	60	65	70	KHz
Green mode frequency (RT = 100KΩ)	3	18	22	28	KHz
Temp. stability (-40°C ~ 110°C)	3			3	%
Voltage stability (Vcc = 11V ~ 25V)	3			3	%

GATE DRIVER OUTPUT

Output low level, VCC = 15V, Io = 20mA	1			1	V
Output high level, VCC = 15V, Io = 20mA	1	8			V
Rising time, load capacitance = 1000pF	1		200		nS
Falling time, load capacitance = 1000pF	1		50		nS
Gate clamping voltage		12.5	13.5	14.7	V

OLP

OLP trip level, Vcomp (OLP)	-	3.3	3.6	4	V
OLP delay time (note), Fs = 65KHz	-		60		mS



Typical Performance Characteristics

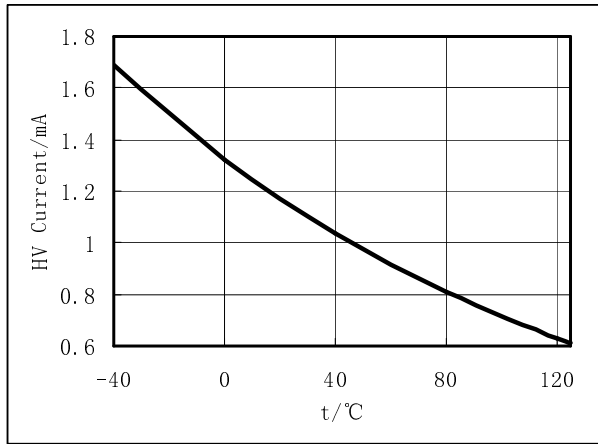

Fig. 1

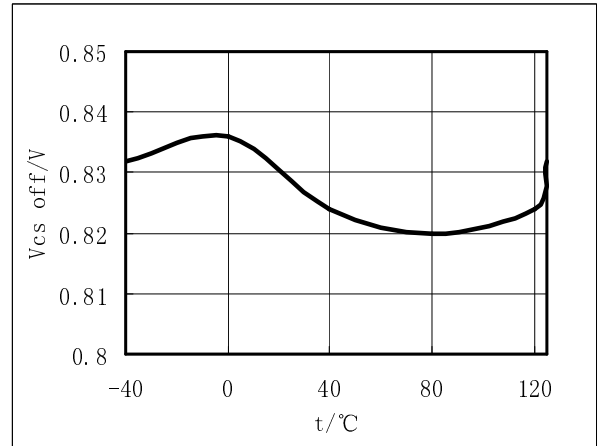

Fig. 2

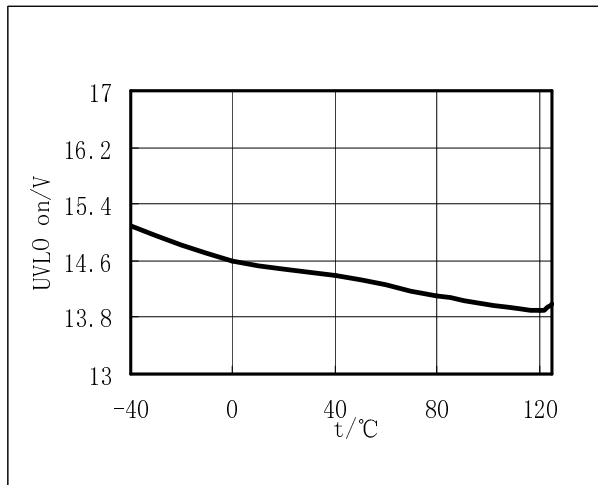

Fig. 3

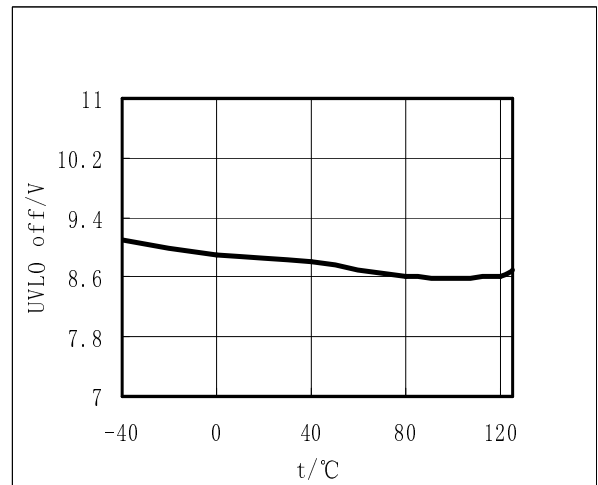

Fig. 4

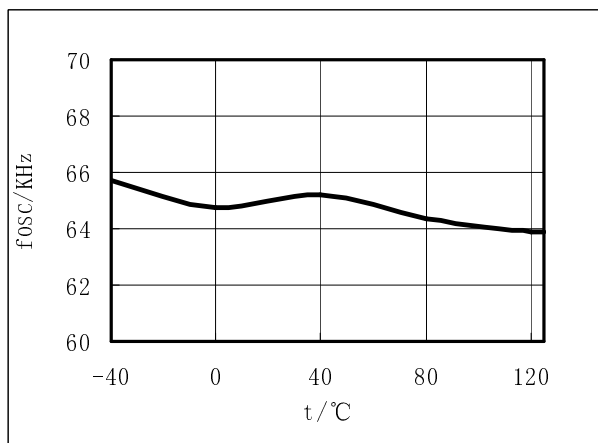

Fig. 5

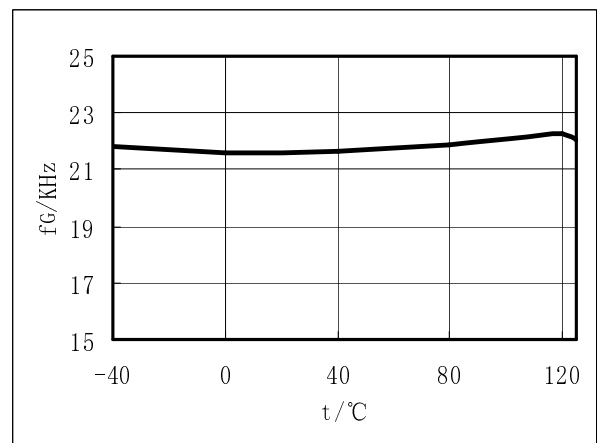

Fig. 6



Typical Performance Characteristics (Cont.)

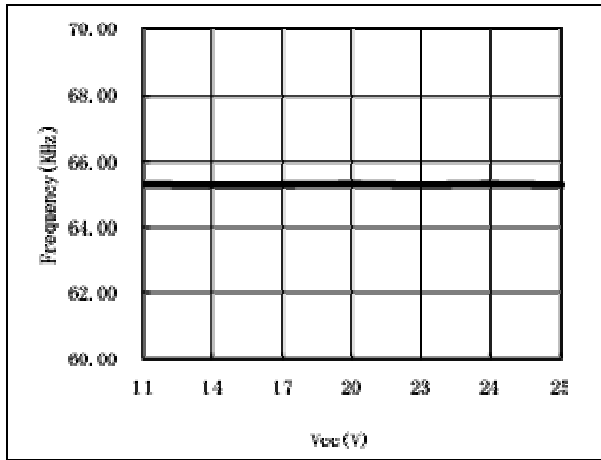

Fig. 7

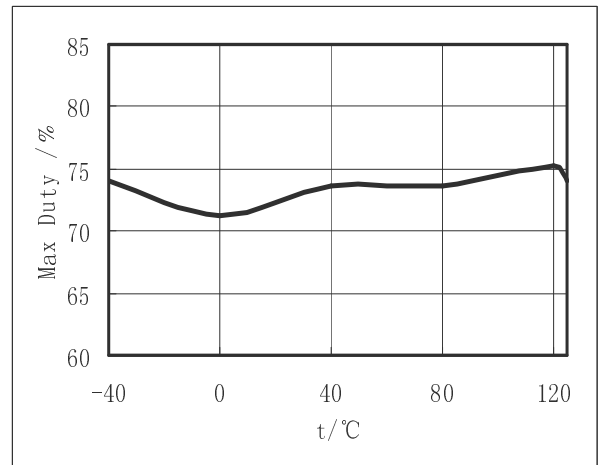

Fig. 8

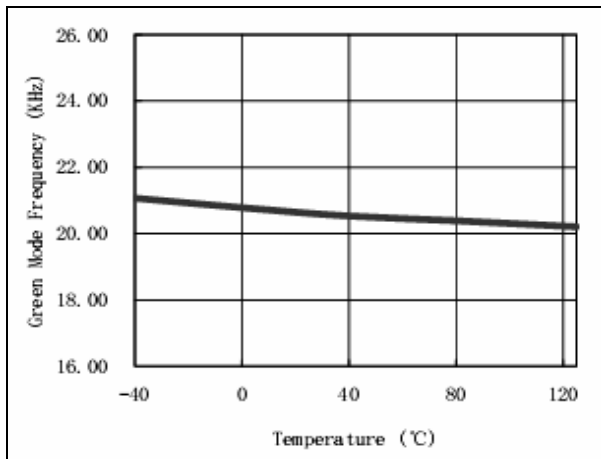

Fig. 9

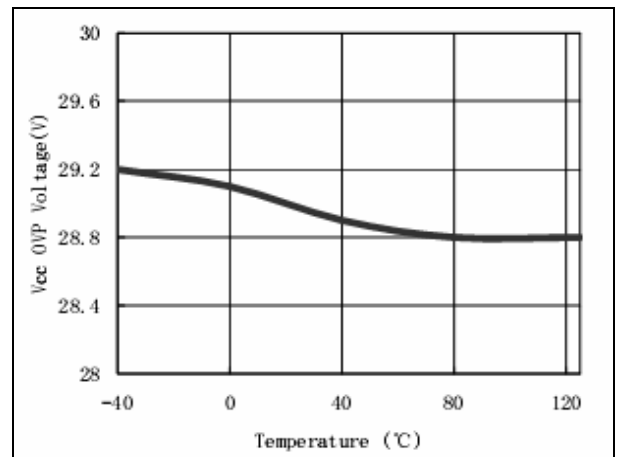

Fig. 10

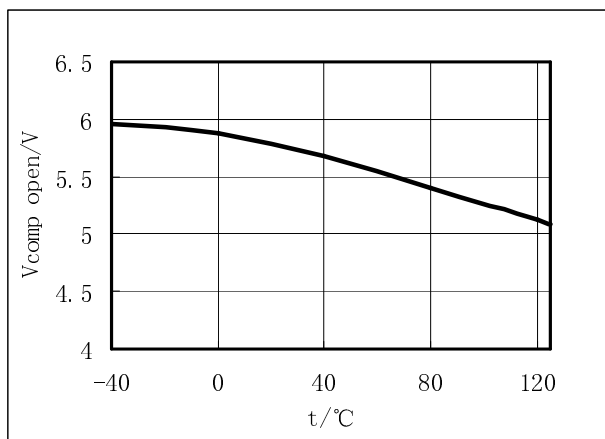

Fig. 11

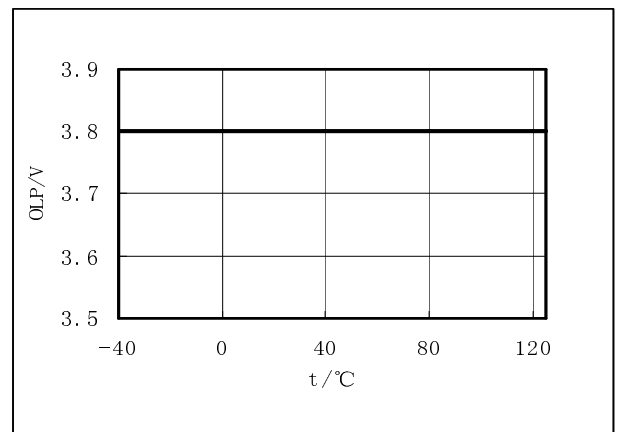

Fig. 12

Application Information

Overview

The GR8874 integrates several functions that are needed in the market. It includes green-mode controller and high-voltage start-up circuit which can save the power loss after startup.

High-voltage Startup Circuit and Under-voltage Lockout (UVLO)

GR8874 implements a high-voltage startup circuit, during the startup; high-voltage current sources are turned on and provide the start-up current as well as charge the Vcc capacitor. When the Vcc voltage is higher than the UVLO (on) threshold, the high-voltage current source will be turned off. Its leakage current is very low (25uA), which only consumes little power. By using such configuration, the traditional startup resistor is not needed and turn-on delay time will be almost the same no matter what the line voltage conditions are (Refer to Fig. 13).

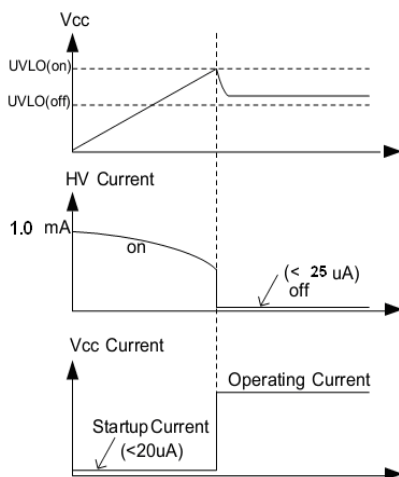

Fig. 13

A hysteresis UVLO comparator is implemented in GR8874, and then the turn-on and turn-off threshold levels are fixed at 15V and 9.3V respectively. This hysteresis shown in Fig.13 ensures that the start-up capacitor will be adequate to supply the chip during start-up.

Oscillator

The maximum duty-cycle of internal oscillator is limited to about 75% to avoid the transformer saturation. The frequency of the oscillator is decided by an external resistor connected from RT pin to ground.

$$f_{osc} = 6500(\text{KHz})/R(\text{Kohm}).$$

Where R is the resistor connected at RT pin. A 100Kohm resistor results in 65KHz switching frequency. The recommended range of oscillation frequency is 50 KHz ~ 130 KHz.

Green-mode Operation

When the load decreases to an extent, the frequency of the controller will decrease so as to reduce the system power consumption. The minimum frequency is about 22 KHz which is outside the audio range.

Leading-edge Blanking (LEB)

Each time the power MOSFET is switched on, a turn-on spike will inevitably occur at the sensor resistor. To avoid fault trigger, a 350ns leading-edge blanking time is built in. Conventional RC filtering can therefore be omitted. During this blanking period, the current-limit comparator is disabled and cannot switch off the gate driver.

Internal Slope Compensation

A built-in slope compensation circuit is constructed in GR8874. When the switch is on, a ramp voltage is added to the sensed voltage across the CS pin, which helps to stabilize the system and prevent sub-harmonic oscillations.

Gate Clamp/Soft Driving

Driver is clamped by an internal 13.5V Zener diode. Those damages usually come from undesired over-voltage gate signals. Under the conditions listed below, the gate output will turn off immediately to protect the power circuit.

The GR8874 also has soft driving function to minimize EMI.

Soft Start

During initial power on, the GR8874 provides soft start function. It effectively suppresses the start up peak current to reduce the power MOSFET drain voltage especially at high line.

Over-load Protection (OLP)

The controller has an over load protection function. An internal circuit detects the Comp pin level, when the level is larger than a threshold and the condition lasts more than 60ms, then the gate output will keep low level. The VCC will decrease to UVLO off level and the controller will be reset again. Fig.14 shows the waveform of the OLP operation.

will recover at the next UVLO (on). The VCC is working in hiccup mode.

Fault Protections

There are several critical protections integrated in the GR8874 to prevent the power supply or adapter from being damaged. Those damages usually come from open or short condition on the pins of GR8874. Under the conditions listed below, the gate output will turn off immediately to protect the power circuit:

- . Gate pin short to ground
- . CS pin floating
- . RT pin floating
- . RT pin short to ground

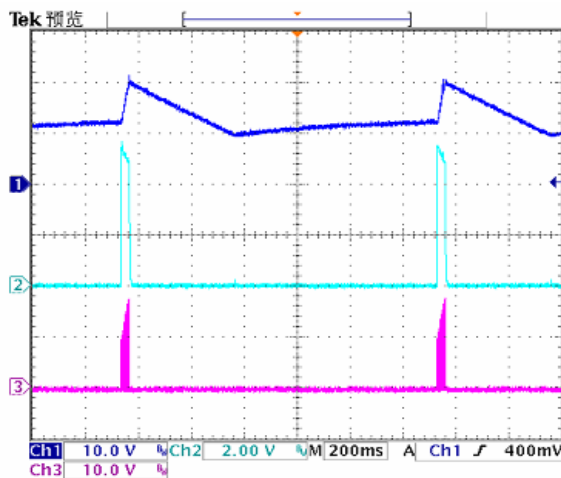
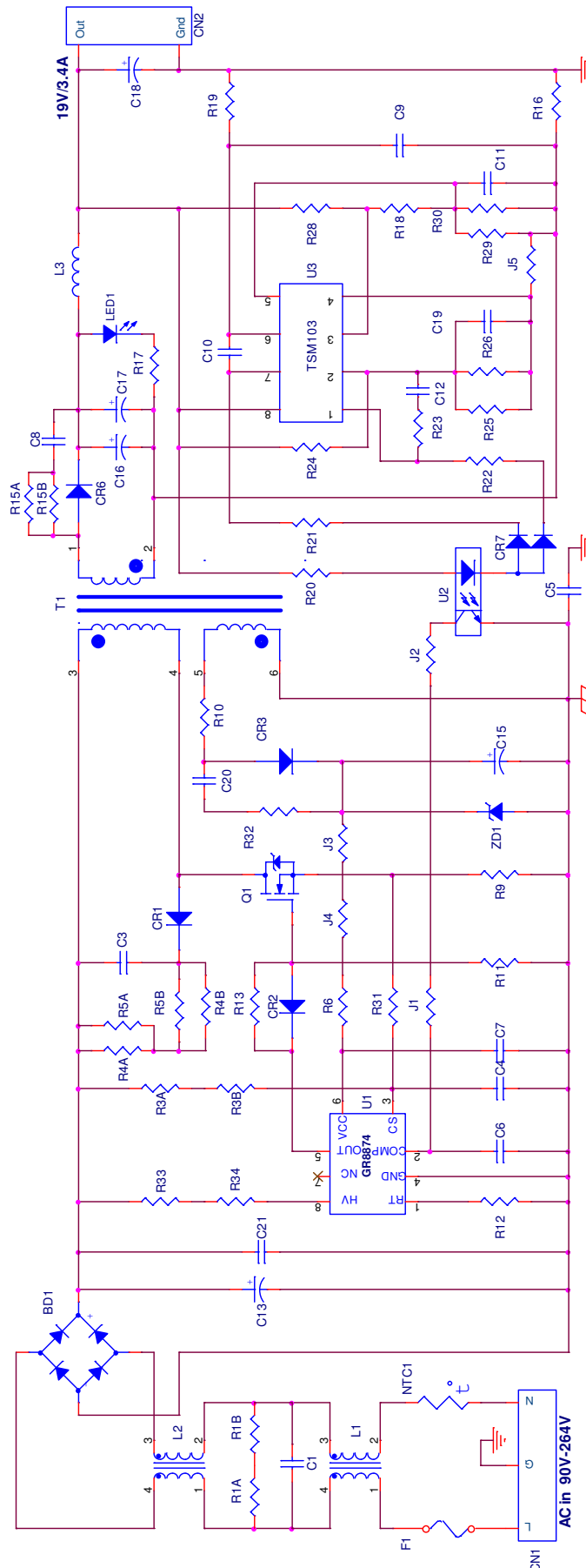

Fig. 14

Over-voltage Protection (OVP) on VCC

To prevent power MOSFET from being damaged, the GR8874 is implemented an OVP function on VCC. When the VCC voltage is higher than the OVP threshold voltage 28V, the output gate driver circuit will be shut down immediately to stop the switching of power MOSFET. The VCC OVP function is an auto-recovery type. If the OVP condition happens, the OUT pin will be disabled and

Typical Application Circuit

Bom List

No.	Part	Description	Quan.
1	BD1	Bridge, KBL406, DIP	1
2	C1	X-cap, 0.47uF, 275V, DIP	1
3	C2, C14, C20,C21	N.A.	
4	C3	Cap,102,1KV, DIP	1
5	C4	Cap,101,50V, SMD 0805	1
6	C5	Y-CAP, CD222, 275V	1
7	C6, C11, C12,C19	Cap,103,50V, SMD 0805	4
8	C7	Cap,104,50V, SMD 0805	1
9	C8	Cap,102, 200V, SMD 0805	1
10	C9	Cap, 225, 50V, SMD 0805	1
11	C10	Cap, 221, 50V, SMD 0805	1
12	C13	E-Cap,120uF, 400V, 105°C, DIP	1
13	C15	E-Cap, 22uF, 50V, 105°C, DIP	1
14	C16, C17	E-Cap, 680uF, 25V, 105°C, DIP, Low ESR	2
15	C18	E-Cap, 220uF, 25V, 105°C,DIP, Low ESR	1
16	CN1	AC Input (3 Pin)	1
17	CR1	FR107, DIP	1
18	CR2	1N4148, SMD	1
19	CR3	FR104, DIP	1
20	CR4, CR5	N.A.	
21	CR6	SBR10U100CT	1
22	CR7	ISS181, SMD	1
23	F1	3.15A, 250V, DIP	1
24	HS1	Heat sink of Rectifier	1
25	HS2	Heat sink of MOSFET	1
26	J1, J2, J3	0R, SMD0805	3
27	J4, J5	0R, SMD1206	2
28	L1	Common Chock, 700uH, DIP	1
29	L2	Common Chock,10mH, DIP	1
30	L3	1.6uH, DIP	1
31	NTC1	N.A.	
32	NTC2	N.A.	

Bom List (Cont.)

33	PCB	FR4, 102mm*39.0mm*1.0mm	1
34	Q1	FPQF10N60,T0220	1
35	Q2	N.A.	
36	Q3	N.A.	
37	R1A, R1B	1M, 5%, SMD1206	2
38	R2, R7, R8, R11, R14, R17, R32	N.A.	
39	R3A, R3B	N.A.	
40	R4A, R4B, R5A, R5B	68K, 5%, SMD1206	4
41	R6, R33, R34	0R, SMD0805	3
42	R9	0.33R, 1W, 1%, Rcs	1
43	R10	2.2R, 5%, SMD1206	1
44	R12	100K, 1%, SMD0805	1
45	R13	33R, 5%, SMD0805	1
46	R15A, R15B	22R, 5%, SMD1206	2
47	R16	0.0170R, 4.0mm	1
48	R18	68K, 1%, SMD0805	1
49	R19	62K, 5%, SMD0805	1
50	R20	100R, 5%, SMD0805	1
51	R21	1.5K, 5%, SMD0805	1
52	R22	10R, 5%, SMD0805	1
53	R23	2.2K, 5%, SMD0805	1
54	R24	16.5K, 1%, SMD0805	1
55	R25, R26	5K, 1%, SMD0805	2
56	R28	15K, 5%, SMD0805	1
57	R29,R30	4.3K,1%, SMD0805	2
58	R31	1.5K, 1%, DIP	1
59	T1	P0T-3019, 550uH	1
60	U1	GR8874, SOP-8	1
61	U2	PC817, DIP-4	1
62	U3	TSM103, SOP-8	1
63	ZD1	N.A.	

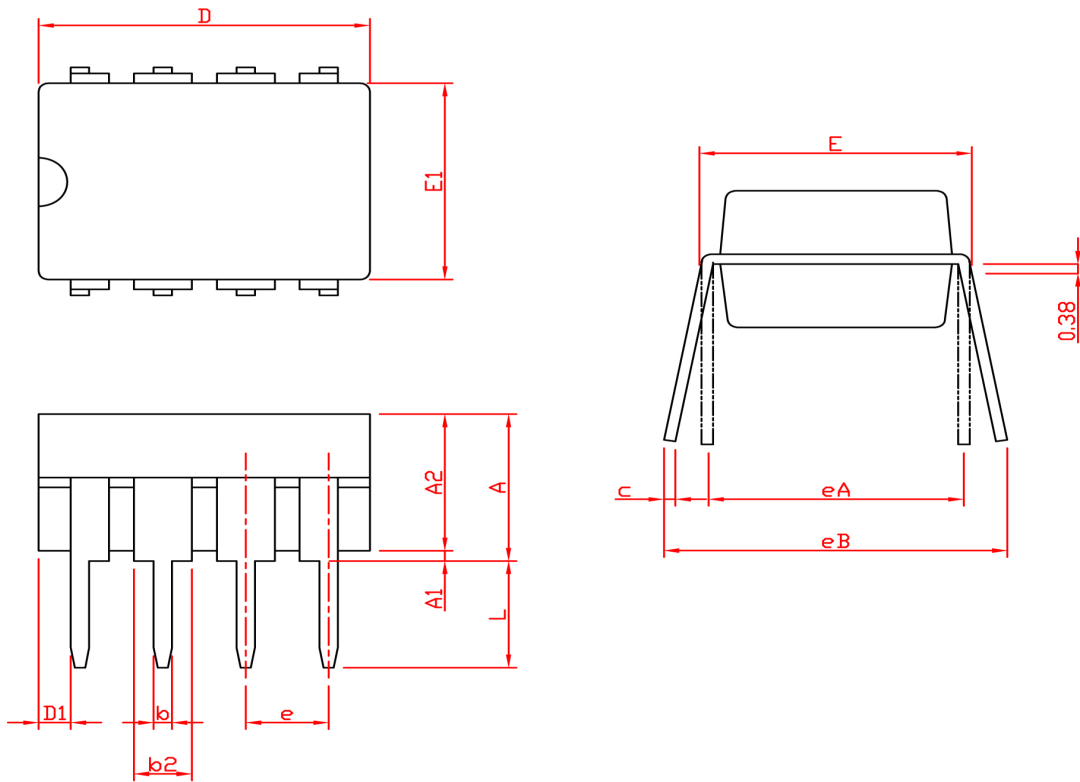
Package Information

SYMBOL	DIP-8			
	MILLIMETERS		INCHES	
	MIN.	MAX.	MIN.	MAX.
A		5.33		0.210
A1	0.38		0.015	
A2	2.92	4.95	0.115	0.195
b	0.36	0.56	0.014	0.022
b2	1.14	1.78	0.045	0.070
c	0.20	0.35	0.008	0.014
D	9.01	10.16	0.355	0.400
D1	0.13		0.005	
E	7.62	8.26	0.300	0.325
E1	6.10	7.11	0.240	0.280
e	2.54 BSC		0.100 BSC	
eA	7.62 BSC		0.300 BSC	
eB		10.92		0.430
L	2.92	3.81	0.115	0.150

Note: 1. Followed from JEDEC MS-001 BA.

2. Dimension D, D1 and E1 do not include mold flash or protrusions. Mold flash or protrusions shall not exceed 10 mil.

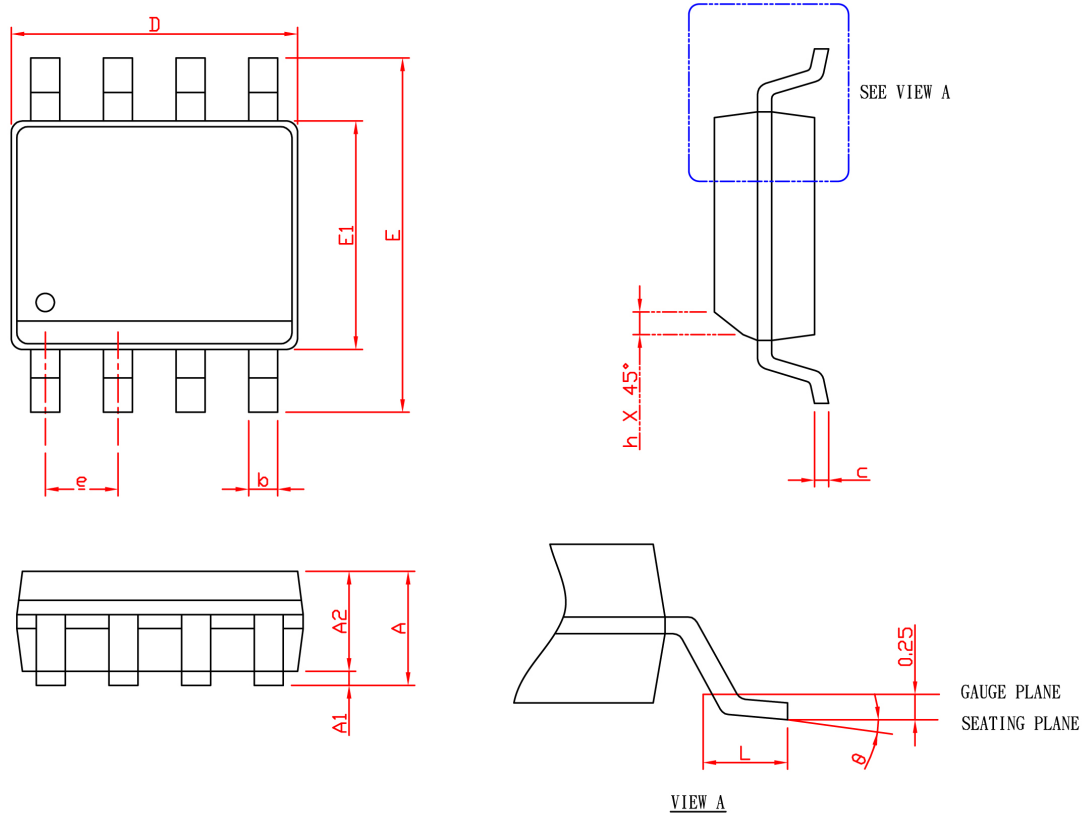
Package Information

SYMBOL	SOP-8			
	MILLIMETERS		INCHES	
	MIN.	MAX.	MIN.	MAX.
A		1.75		0.069
A1	0.10	0.25	0.004	0.010
A2	1.25		0.049	
b	0.31	0.51	0.012	0.020
c	0.17	0.25	0.007	0.010
D	4.80	5.00	0.189	0.197
E	5.80	6.20	0.228	0.244
E1	3.80	4.00	0.150	0.157
e	1.27 BSC		0.050 BSC	
h	0.25	0.50	0.010	0.020
L	0.40	1.27	0.016	0.050
θ	0°	8°	0°	8°

Note: 1. Followed from JEDEC MS-012 AA.

2. Dimension "D" does not include mold flash, protrusions or gate burrs. Mold flash, protrusion or gate burrs shall not exceed 6 mil per side.

3. Dimension "E1" does not include inter-lead flash or protrusions. Inter-lead flash and protrusions shall not exceed 10 mil per side.



Carrier Tape & Reel Dimensions

SOP-8

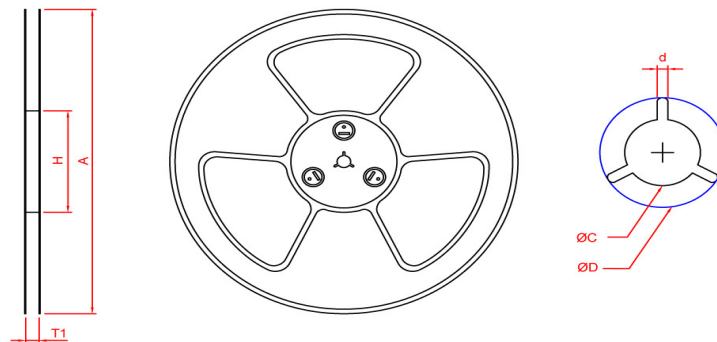
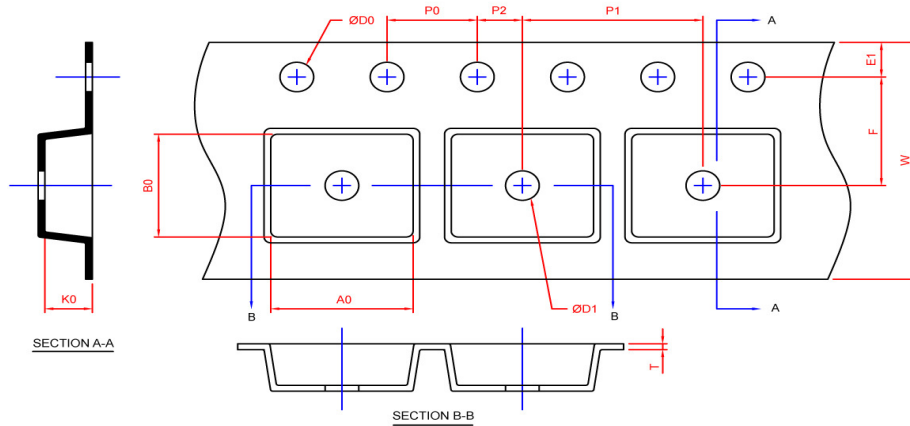

Application	A	H	T1	C	d	D	W	E1	F
SOP-8	330.0±2.0	50 MIN.	12.4+2.00 -0.00	13.0+0.50 -0.20	1.5 MIN.	20.2 MIN.	12.0±0.30	1.75±0.10	5.5±0.05
	P0	P1	P2	D0	D1	T	A0	B0	K0
	4.0±0.10	8.0±0.10	2.0±0.05	1.5+0.10 -0.00	1.5 MIN.	0.6+0.00 -0.40	6.40±0.20	5.20±0.20	2.10±0.20

(mm)

Devices Per Unit

Application	Carrier Width	Cover Tape Width	Devices Per Reel
SOP-8	12	-	2500

Greenergy OPTO, Inc. reserves the right to make corrections, modifications, enhancements, improvements, and other changes to its products and services at any time and to discontinue any product or service without notice. Customers should obtain the latest relevant information before placing orders and should verify that such information is current and complete.