

## Secondary Side Synchronous Rectifier Controller

### Features

- High speed secondary synchronous rectifier
- High system efficiency from no load to full load
- Light load protection function
- DCM topology
- 200V high voltage technology
- Ultra low startup and quiescent current
- Vcc ranges from 11.6V to 19.5V
- SOP-8 green (Halogen free) package

### Description

GR8387 is the synchronous rectifier controller used in discontinuous conduction mode and quasi-resonant flyback converters. The IC controls N-MOSFET to substitute Schottky diode. The VD to VS voltage difference is sensed to decide the polarity of the current and turn the power switch on/off in nearly of zero current transition. When light load the gate driver output can be disable to avoid long MOSFET turn on period.

### Applications

- ATX power supply
- NB adapter
- LCD TV
- SMPS

### Ordering and Marking Information

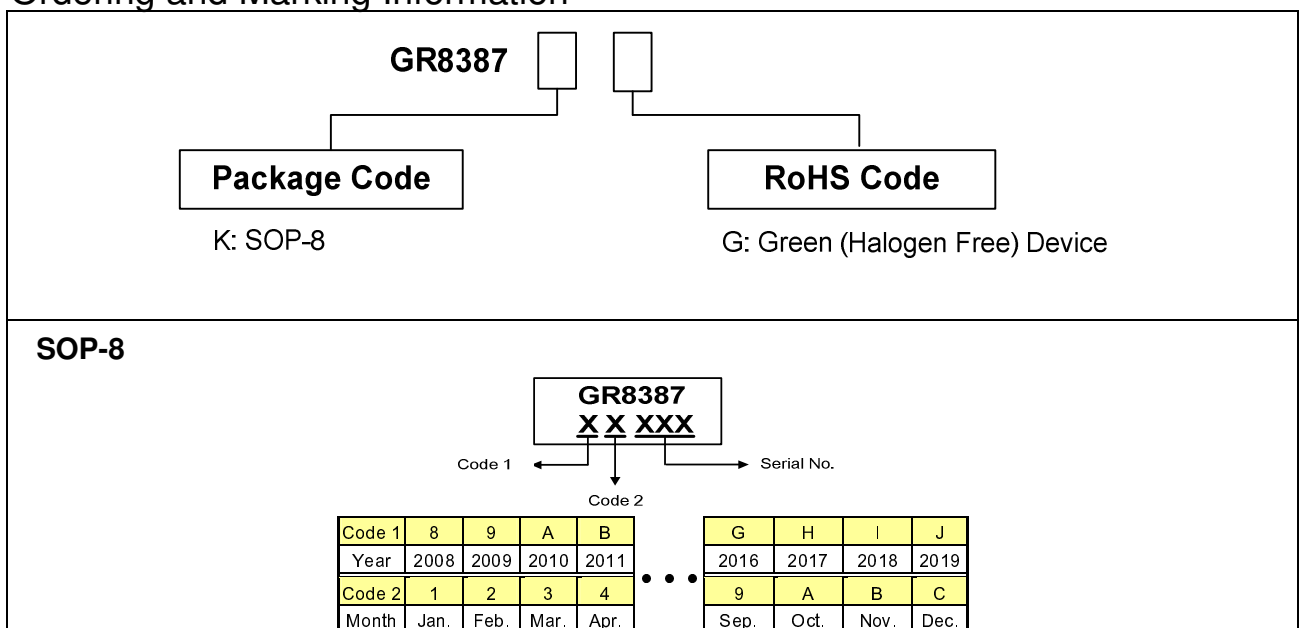

Greenergy OPTO Inc. reserves the right to make changes to improve reliability or manufacture ability without notice, and advise customers to obtain the latest version of relevant information to verify before placing orders.

## Pin Configuration

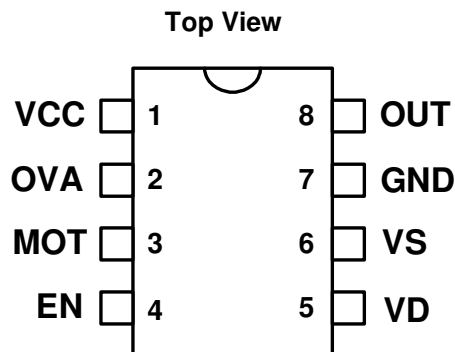

## Pin Descriptions

Pin No.	Name	Function
1	VCC	Supply voltage
2	OVA	Offset voltage altering
3	MOT	Minimum on time setting
4	EN	Enable (Internal pull high)
5	VD	MOSFET drain voltage sensing
6	VS	MOSFET source voltage sensing
7	GND	Ground
8	OUT	Gate drive output

## Absolute Maximum Ratings

VCC, EN, VS, OUT	-----	- 0.3V ~ 20V
VD (Continued and pulsed)	-----	-3V ~ 180V
Operating junction temperature	-----	-40°C ~ 150°C
Storage temperature	-----	-55°C ~ 150°C
SOP-8 package thermal resistance	-----	160°C/W
Power dissipation (SOP-8, at ambient temperature = 85°C)	-----	400mW
ESD protection (Human body mode)	-----	2KV
ESD protection (Machine Mode)	-----	200V
Switching frequency	-----	500KHz

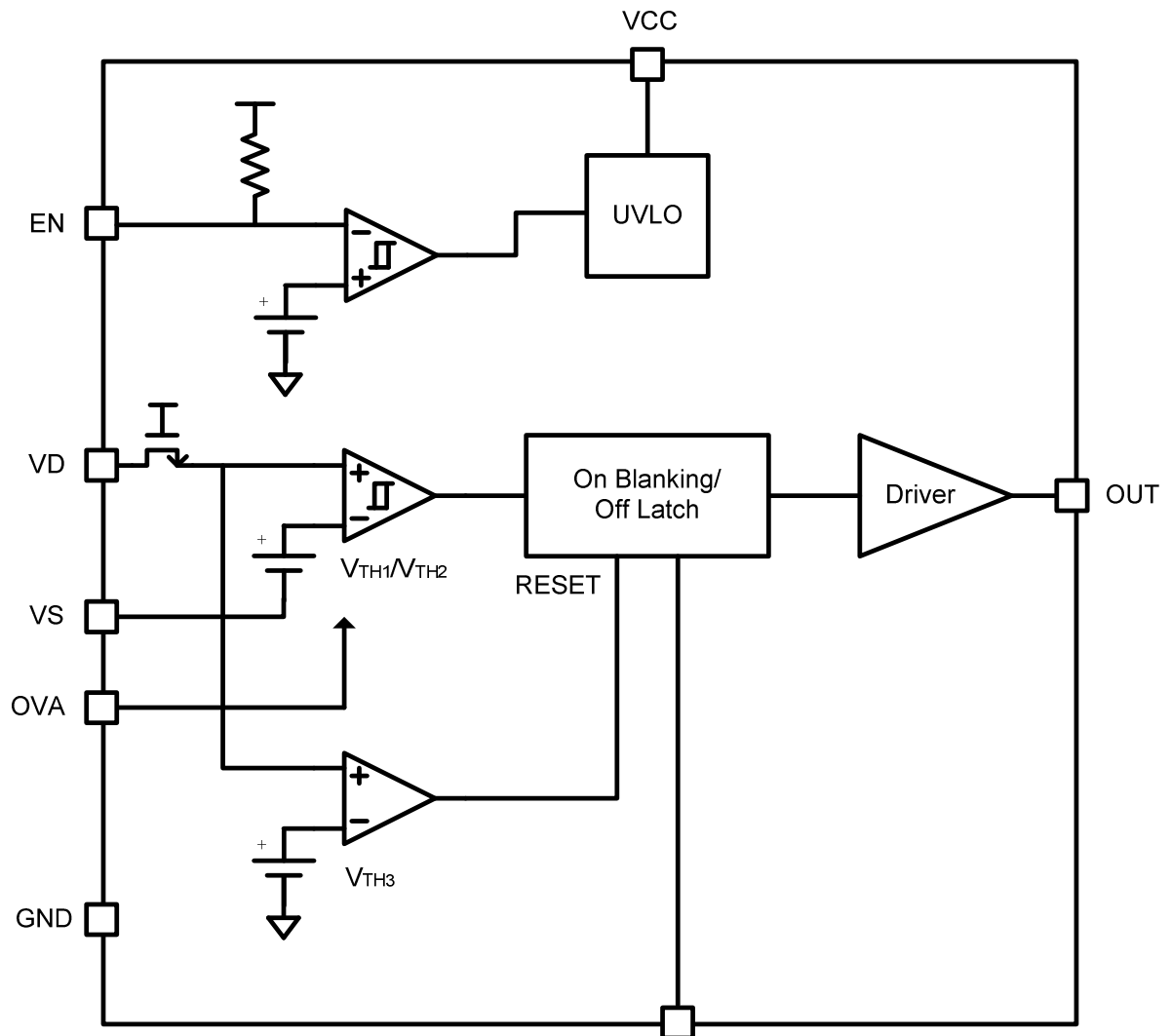
**Block Diagram**

**Electrical Characteristics** (VCC = 15V, Ta = 25°C, unless otherwise specified)

Parameter	Conditions	Symbol	Min.	Typ.	Max.	Unit
-----------	------------	--------	------	------	------	------

**SUPPLY SECTION**

Supply voltage operating range		VCC	11.6		19.5	V
VCC turn on threshold		VCC ON	9.7	10.5	11.2	V
VCC turn off threshold		VCC UVLO	8.4	9	9.6	V
VCC turn on/off hysteresis		VCC HYST	1.4	1.57	1.7	V
Operating current	CLOAD = 1nF, fsw = 500kHz	ICC		9	13	mA
	CLOAD = 10nF, fsw = 500kHz			57	69	mA
Quiescent current		IQCC		1.5	2.2	mA
Start-up current	VCC = VCC ON - 0.1V	ICC START		90	140	μA
Sleep current	VEN = 0V, VCC = 15V	ISLEEP		160	200	μA
Enable voltage high		VENHI		2.71		V
Enable voltage low		VENLO		1.6		V
Enable pull-up resistance		REN		1.5		MΩ

**COMPARATOR SECTION**

Turn-off threshold	OVT = 0V, VS = 0V	VTH1	-7.5	-4	0	mV
	OVT floating, VS = 0V		-15	-11	-7.5	
	OVT = VCC, VS = 0V		-24	-19.5	-15	
Turn-on threshold		VTH2	-150		-50	mV
Input bias current		IIBIAS1		1	7.5	μA
Input bias current	VD = 200V	IIBIAS2		23	100	μA
Comparator input offset		VOFFSET			2	mV
Input CM voltage range		VCM	-0.15		2	V

**NOISE REJECT SECTION**

Minimum on time	RMOT = 5kΩ, VCC = 12V	TONmin	240	290	350	ns
	RMOT = 75kΩ, VCC = 12V		2.8	3.5	4.2	μs
Reset threshold VTH3	VCC = 10V - GBD	VTH3		2.5		V
	VCC = 20V - GBD			5.4		V
Hysteresis	VCC = 10V - GBD	VHYST3		40		mV

**Electrical Characteristics (Cont.)**

Parameter	Conditions	Symbol	Min.	Typ.	Max.	Unit
<b>GATE DRIVER SECTION</b>						
Gate low voltage	IGATE = 200mA	VGLO		0.2	0.5	V
Gate high voltage	VCC = 12V-18V (internally clamped)	VGTH	9.5	11	12.5	V
Rise time	CLOAD = 1nF, VCC = 12V	tr1		20		ns
	CLOAD = 10nF, VCC = 12V	tr2		270		ns
Fall time	CLOAD = 1nF, VCC = 12V	tf1		8.5		ns
	CLOAD = 10nF, VCC = 12V	tf2		42		ns
Turn on propagation delay	VDS to VGATE -100mV overdrive	tDon		130	160	ns
Turn off propagation delay	VDS to VGATE -100mV overdrive	tDoff		90	110	ns
Pull up resistance	IGATE = 1A - GBD	rup		5		Ω
Pull down resistance	IGATE = -200mA	rdown		1.7		Ω
Output peak current (source)	CLOAD = 10nF - GBD	IO source		1		A
Output peak current (sink)	CLOAD = 10nF - GBD	IO sink		4		A



## Application Information

### Overview

GR8387, the secondary side driver IC, emulates the operation of diode rectifier by driving a synchronous rectifier MOSFET. Using low  $R_{DS\_ON}$  N-MOSFET to substitute Schottky diode, the lower turn-on voltage will reduce conduction loss on rectifier. The efficiency of power converter will be boosted.

### Under-Voltage Lockout (UVLO)

The GR8387 remains off until VCC voltage exceeds VCC turn-on threshold voltage (VCC\_ON). As the IC is off, it takes as little current as 75 $\mu$ A. Once the VCC rises above VCC\_ON, the IC starts to work. It continues to operate until the voltage drops below VCC turn-off threshold voltage (VCC\_OFF).

### Sleeping / Normal Mode

Since the GR8387 Vcc pin voltage exceeds VCC\_ON, there are two modes available, sleeping mode and normal mode. The IC will be in sleeping mode as EN pin is pulled low. In this mode, the IC draws a very low quiescent supply current and MOSFET goes into off state. As EN pin is pulled high, the IC will be in normal mode. In this mode, MOSFET starts to switch, and the IC needs higher supply current to support function blocks working.

### OUT Pin Turn on/off Phase

As secondary side rectifier is in conduction state, (Fig.1, T2) the rectifier current flows through the body diode of the MOSFET at first, which will generate a negative VDS voltage on the MOSFET. The negative voltage will be below turn-on threshold voltage (VTH2), and then the GR8387 OUT will be pulled high to drive the MOSFET turn on. The current will flow through the channel of the MOSFET and causes the VDS voltage to drop down.

When the MOSFET is turned on, it stays on until the rectifier current reduces to the level while VDS exceeds the turn-off threshold voltage (VTH1). This

makes OUT pin be pulled low and turns the MOSFET off.

### Minimum On time (MOT) and Turn Off Latch

To avoid the mistrigger which is caused by noise as MOSFET is switching, minimum on time (MOT) function and turn off latch control have been built in GR8387. When OUT pin is pulled high, the minimum on time (MOT) which is setting by the resistor between MOT pin to ground keeps the MOSFET on. As OUT pin is pulled low, the MOSFET won't open again until the VDS over reset threshold Voltage (VTH3), which means that the secondary side discharge has finished.

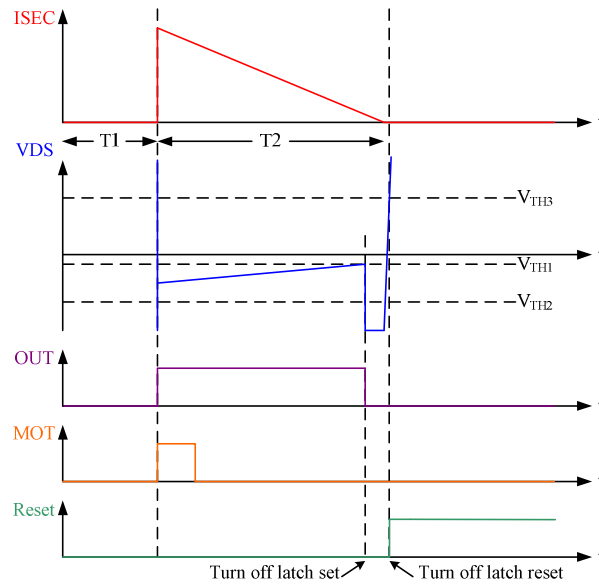
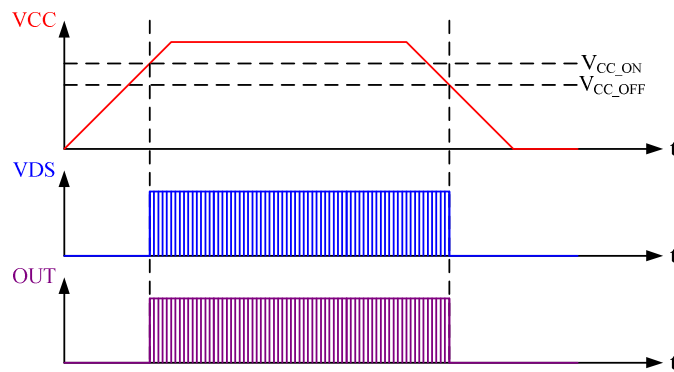
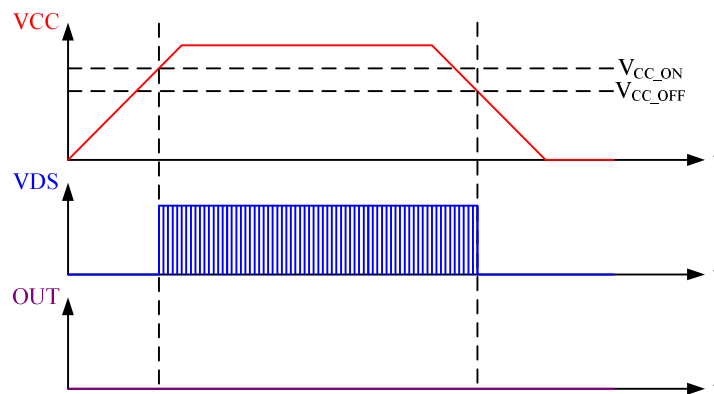
**Fig 1. Secondary Side Operation**

**Fig 2. Normal Mode Operation (EN=H)**

**Fig 3. Sleeping Mode Operation (EN=L)**

## Typical Performance Characteristics

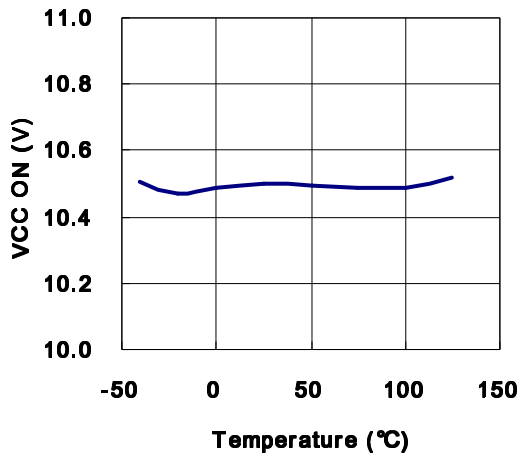

Fig 4. VCC\_ON vs. Temp.

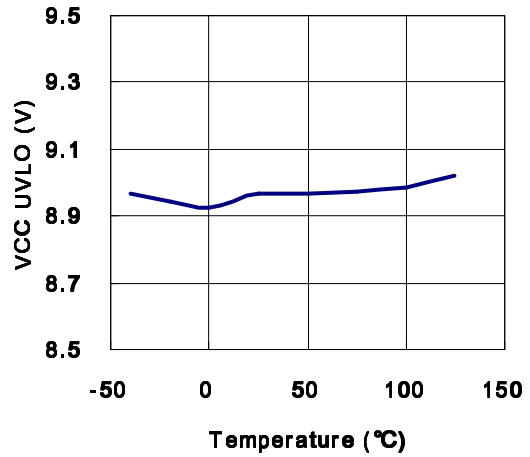

Fig 5. VCC\_UVLO vs. Temp.

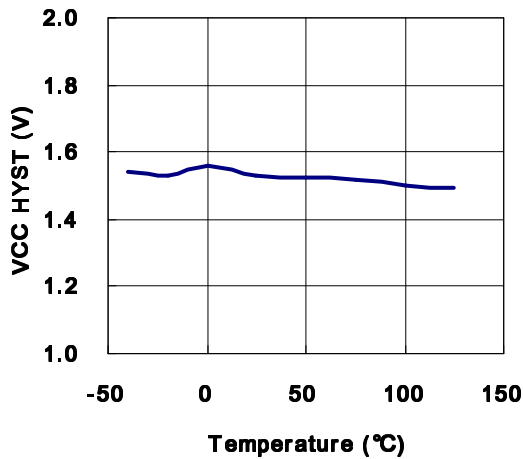

Fig 6. VCC\_HYST vs. Temp.

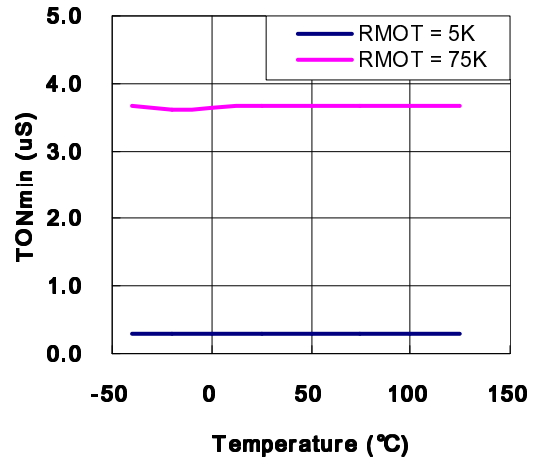

Fig 7. TONmin vs. Temp.

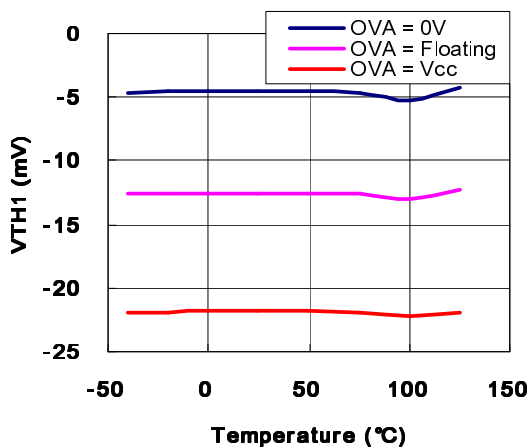
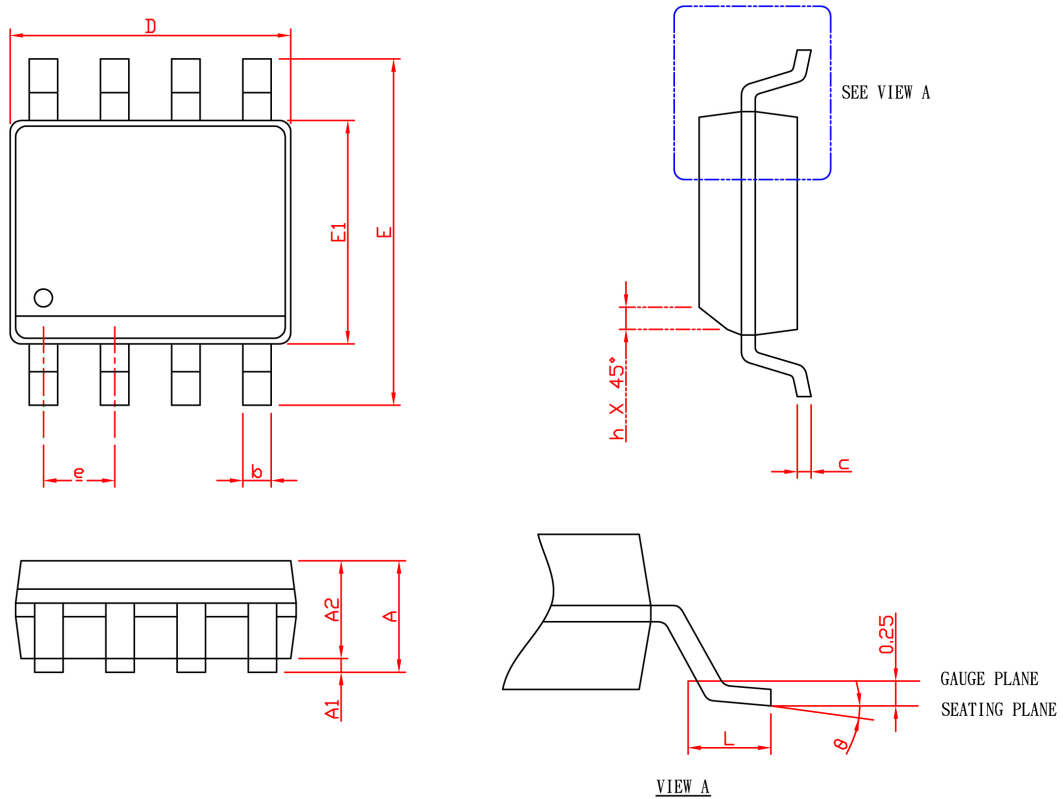

Fig 8. VTH1 vs. Temp.

**Package Information**

SYMBOL	SOP-8			
	MILLIMETERS		INCHES	
	MIN.	MAX.	MIN.	MAX.
A		1.75		0.069
A1	0.10	0.25	0.004	0.010
A2	1.25		0.049	
b	0.31	0.51	0.012	0.020
c	0.17	0.25	0.007	0.010
D	4.80	5.00	0.189	0.197
E	5.80	6.20	0.228	0.244
E1	3.80	4.00	0.150	0.157
e	1.27 BSC		0.050 BSC	
h	0.25	0.50	0.010	0.020
L	0.40	1.27	0.016	0.050
$\theta$	0°	8°	0°	8°

Note: 1. Followed from JEDEC MS-012 AA.

2. Dimension "D" does not include mold flash, protrusions or gate burrs. Mold flash, protrusion or gate burrs shall not exceed 6 mil per side.
3. Dimension "E1" does not include inter-lead flash or protrusions. Inter-lead flash and protrusions shall not exceed 10 mil per side.

## Carrier Tape & Reel Dimensions

### SOP-8

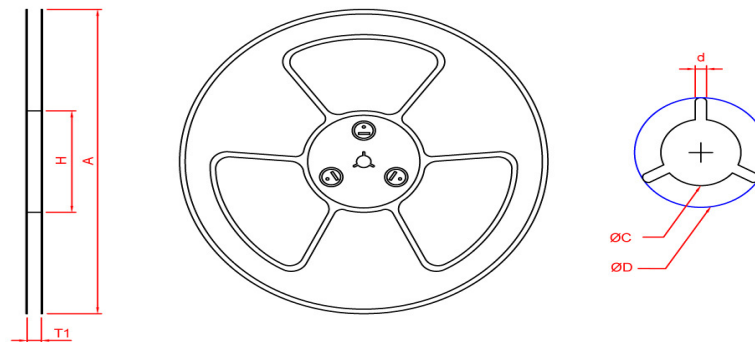
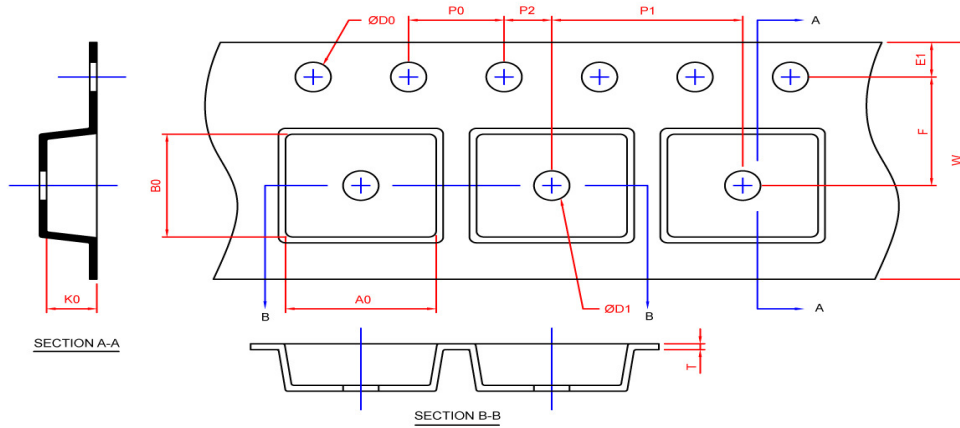

Application	A	H	T1	C	d	D	W	E1	F
SOP-8	330.0±2.0	50 MIN.	12.4+2.00 -0.00	13.0+0.50 -0.20	1.5 MIN.	20.2 MIN.	12.0±0.30	1.75±0.10	5.5±0.05
	P0	P1	P2	D0	D1	T	A0	B0	K0
	4.0±0.10	8.0±0.10	2.0±0.05	1.5+0.10 -0.00	1.5 MIN.	0.6+0.00 -0.40	6.40±0.20	5.20±0.20	2.10±0.20

(mm)

### Devices Per Unit

Application	Carrier Width	Cover Tape Width	Devices Per Reel
SOP-8	12	-	2500

Greenergy OPTO, Inc. reserves the right to make corrections, modifications, enhancements, improvements, and other changes to its products and services at any time and to discontinue any product or service without notice. Customers should obtain the latest relevant information before placing orders and should verify that such information is current and complete.