

Monitor and Timing Management for 2-Parallel NiMH Battery Charger

Features

- Charges 1 to 2 NiMH packs
- Detects and avoids charging alkaline cells
- Monitors voltage, temperature and time for safety and secondary termination
- Drivers PNP type pass element
- Pre-charge qualification for detecting shorted, damaged, or deeply depleted cells
- Automatic recharge keeps batteries charged
- Optional temperature qualified charging

Applications

- Portable computer, cellular phone and PDA
- Charging docks and cradles
- Portable consumer electronics
- Desktop/standalone charger (AAA/AA)
- Digital still camera
- Music players (MP3)
- Game
- Toy
- Emergency light

Description

The GR5301 is ideal for standalone charging of 1 or 2 or 4 of AA or AAA NiMH “loose” cells. NiCd cells can also be charged. Temperature, voltage and charge time are monitored to provide proper fast/slow charging control algorithms for Nickel Metal Hydride (NiMH) batteries. The GR5301 detects the battery chemistry and proceeds with the optimal charging and termination algorithms. This process eliminates undesirable undercharged or overcharged conditions and allows accurate and safe termination of fast/slow charge. Battery tests are included to detect defective or inappropriate cells such as Alkaline primary batteries. The GR5301 supports two loops charging topology, with independent monitoring and control of each loop.

Ordering and Marking Information

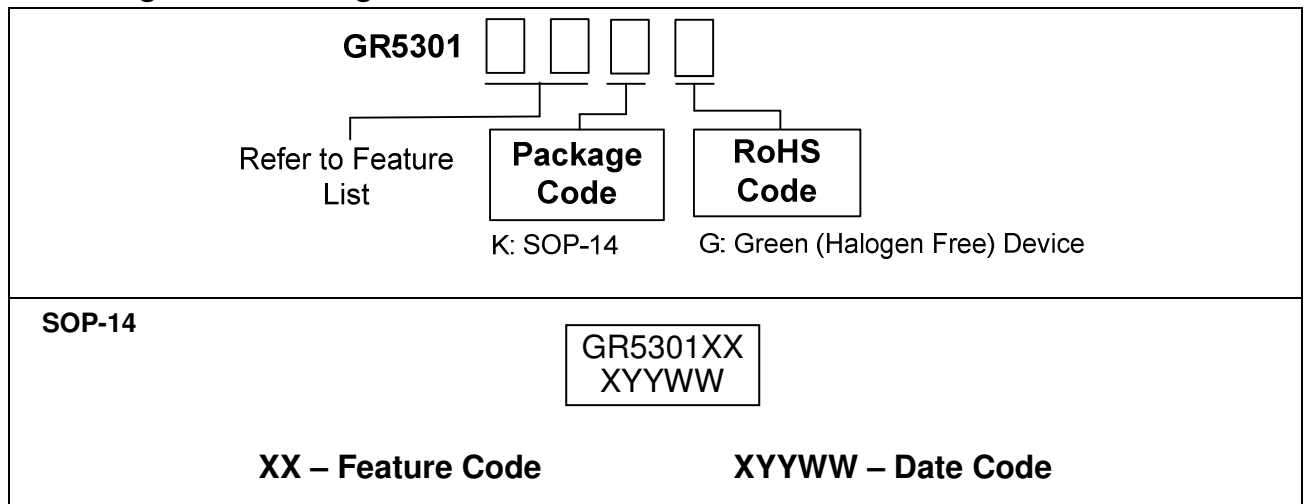

Greenergy OPTO Inc. reserves the right to make changes to improve reliability or manufacture ability without notice, and advise customers to obtain the latest version of relevant information to verify before placing orders.

Feature List

	Fixed Timing	Adjusted Timing	Single LED
Single Cell	GR5301AA (SOP-14)	GR5301AT (SOP-14)	GR5301AS (SOP-14)
Dual Cell	GR5301DA (SOP-14)	GR5301DT (SOP-14)	GR5301DS (SOP-14)

Pin Configuration

GR5301 AA/DA TOP VIEW

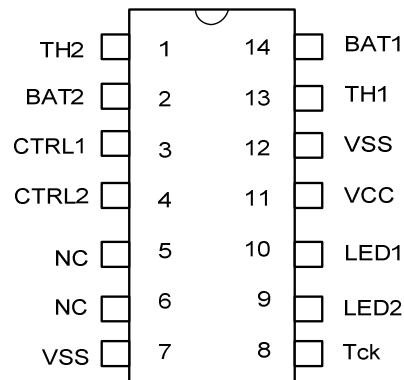

Pin Description

Pin No.	Symbol	Description
1	TH2	Thermistor input for Slot 2
2	BAT2	Slot 2, battery voltage input
3	CTRL1	Slot 1, charge switch control
4	CTRL2	Slot 2, charge switch control
5, 6	NC	Not connect
7, 12	VSS	Negative power supply
8	Tck	Tck for test mode and time selection
9	LED2	Slot 2 charge/ Full status LED indicator
10	LED1	Slot 1 charge/ Full status LED indicator
11	VCC	Positive power supply
13	TH1	Thermistor input for Slot 1
14	BAT1	Slot 1, battery voltage input

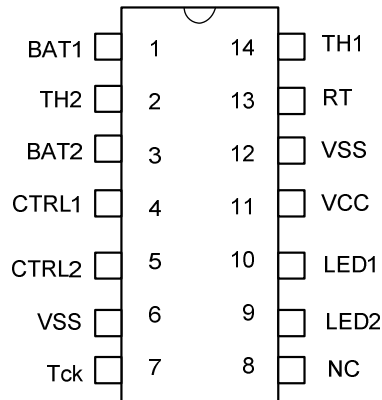
GR5301 AT/DT TOP VIEW

Pin Description

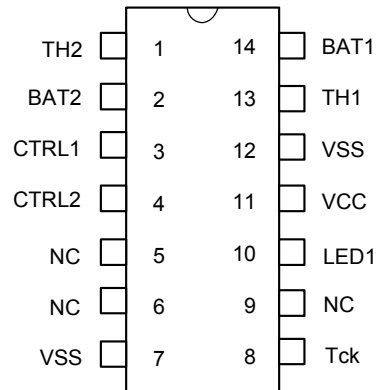
Pin No.	Symbol	Description
1	BAT1	Slot 1, battery voltage input
2	TH2	Thermistor input for Slot 2
3	BAT2	Slot 2, battery voltage input
4	CTRL1	Slot 1, charge switch control
5	CTRL2	Slot 2, charge switch control
6, 12	VSS	Negative power supply
7	Tck	Tck for test mode and time selection
8	NC	Not connect
9	LED2	Slot 2 charge/ Full status LED indicator
10	LED1	Slot 1 charge/ Full status LED indicator
11	VCC	Positive power supply
13	RT	Timing Resistor
14	TH1	Thermistor input for Slot 1

GR5301 AS/DS TOP VIEW

Pin Description

Pin No.	Symbol	Description
1	TH2	Thermistor input for Slot 2
2	BAT2	Slot 2, battery voltage input
3	CTRL1	Slot 1, charge switch control
4	CTRL2	Slot 2, charge switch control
5, 6, 9	NC	Not connect
7, 12	VSS	Negative power supply
8	Tck	Tck for test mode and time selection
10	LED1	Slot 1 charge/ Full status LED indicator
11	VCC	Positive power supply
13	TH1	Thermistor input for Slot 1
14	BAT1	Slot 1, battery voltage input

Absolute Maximum Ratings

Input voltage between VCC and VSS	VSS -0.3 ~ VSS +5.5V
Battery voltage input	VSS -0.3 ~ VSS +5V
LED sink current	4mA
LED driver current	4mA
Operating temperature range	0 to +85 °C
Storage temperature range	-40 to +125 °C

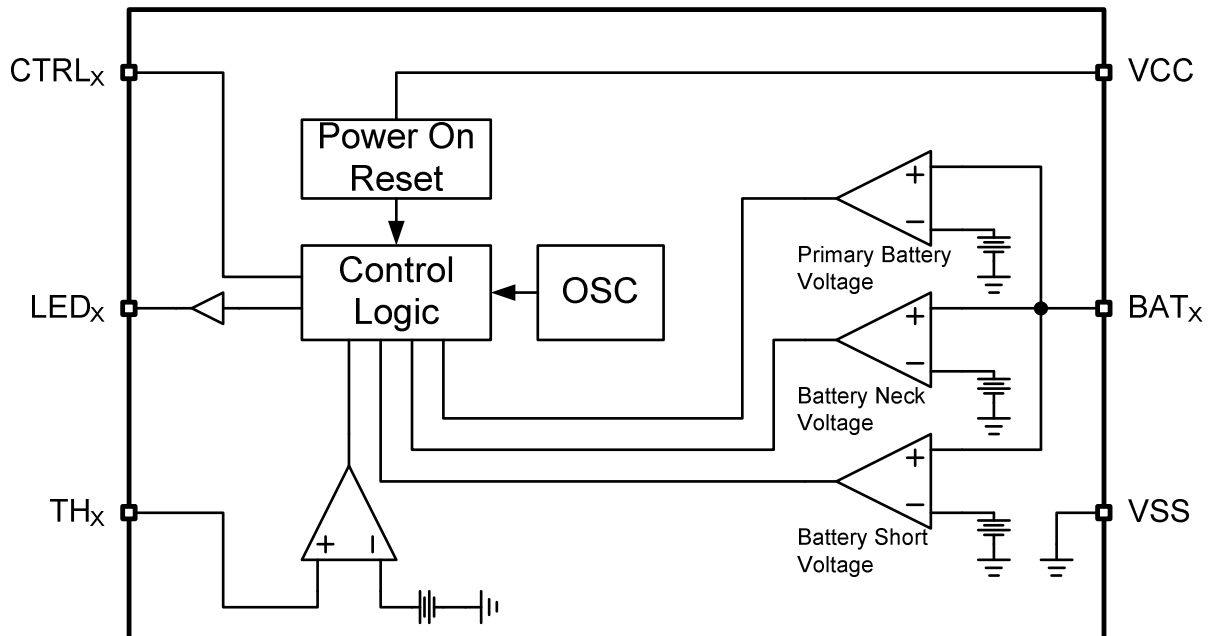
Block Diagram



Electrical Characteristics (T_A = 25°C)

Parameter	Conditions	Symbol	Min	Typ	Max	Unit
-----------	------------	--------	-----	-----	-----	------

POWER SUPPLY

Operating Voltage		V _{CC}	4.5	5.0	5.5	V
Supply Current	V _{CC} = 5V	I _{CC}	0.4	0.5	0.6	mA
Battery Voltage Input	GR5301AA	V _{BAT}	0.5		2	V
	GR5301AT	V _{BAT}	0.5		2	V
	GR5301AS	V _{BAT}	0.5		2	V
	GR5301DA	V _{BAT}	1		4	V
	GR5301DT	V _{BAT}	1		4	V
	GR5301DS	V _{BAT}	1		4	V
LED Sink Current	V _{CC} = 5V	I _{LED-SINK}	2.5	3	3.5	mA
LED Driver Current	V _{CC} = 5V	I _{LED-Driver}	2.5	3	3.5	mA
Thermistor Input		V _{TH}	1.07	1.12	1.17	V

PROTECTION VOLTAGE

Battery Short Voltage		Vshort	0.45	0.5	0.55	V
Primary Battery Voltage	GR5301AA	Vprimary	1.575	1.6	1.625	V
	GR5301AT	Vprimary	1.575	1.6	1.625	V
	GR5301AS	Vprimary	1.575	1.6	1.625	V
	GR5301DA	Vprimary	3.15	3.2	3.25	V
	GR5301DT	Vprimary	3.15	3.2	3.25	V
	GR5301DS	Vprimary	3.15	3.2	3.25	V
Battery Neck Voltage	GR5301AA	Vneck	1.395	1.42	1.445	V
	GR5301AT	Vneck	1.395	1.42	1.445	V
	GR5301AS	Vneck	1.395	1.42	1.445	V
	GR5301DA	Vneck	2.79	2.84	2.89	V
	GR5301DT	Vneck	2.79	2.84	2.89	V
	GR5301DS	Vneck	2.79	2.84	2.89	V

SAFE TIMER

GR5301AA, GR5301AS, GR5301DA, GR5301DS						
Safe Charge Timer	TCK = HI	Timer	11.5	12	12.5	hour
Safe Charge Timer	TCK = LO	Timer	5.5	6	6.5	hour
GR5301AT, GR5301DT (Note 1)						
Safe Charge Timer	TCK = HI	Timer	2 (RT=200KΩ)	12 (RT=450KΩ)	18 (RT=700KΩ)	hour
Safe Charge Timer	TCK = LO	Timer	1 (RT=200KΩ)	6 (RT=450KΩ)	9 (RT=700KΩ)	hour

Note 1. The timer of GR5301AT and GR5301DT could be any value between min and max by changing RT value.



Typical Application Circuit

GR5301AA/DA

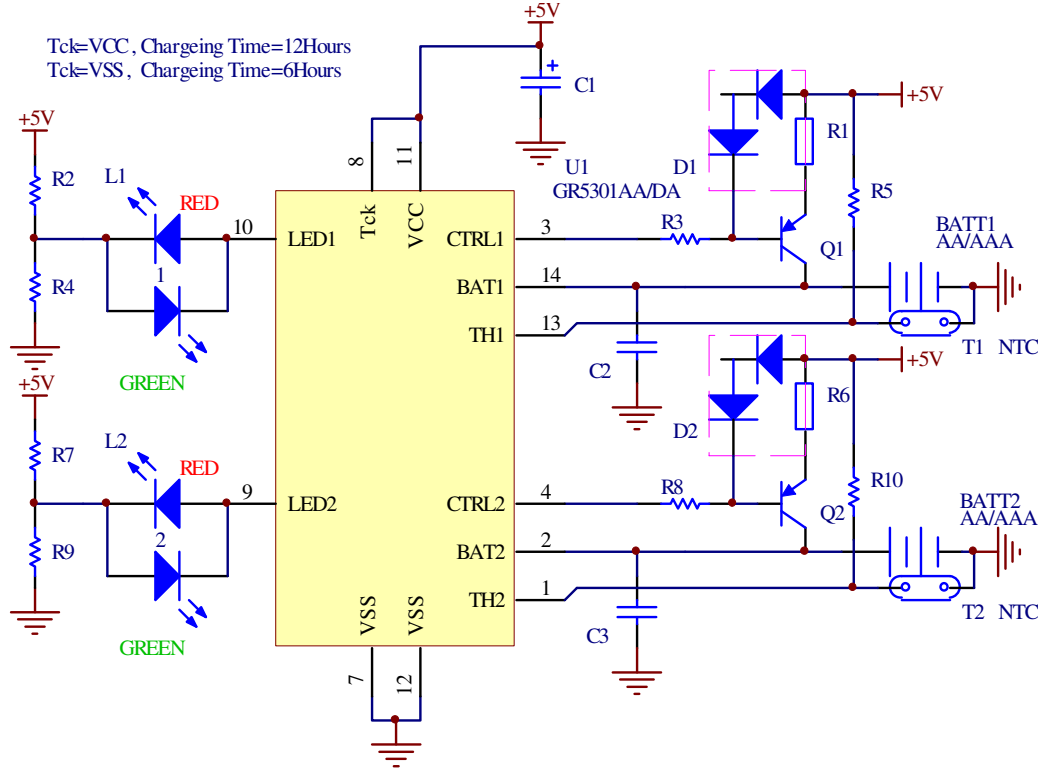

GR5301AT/DT

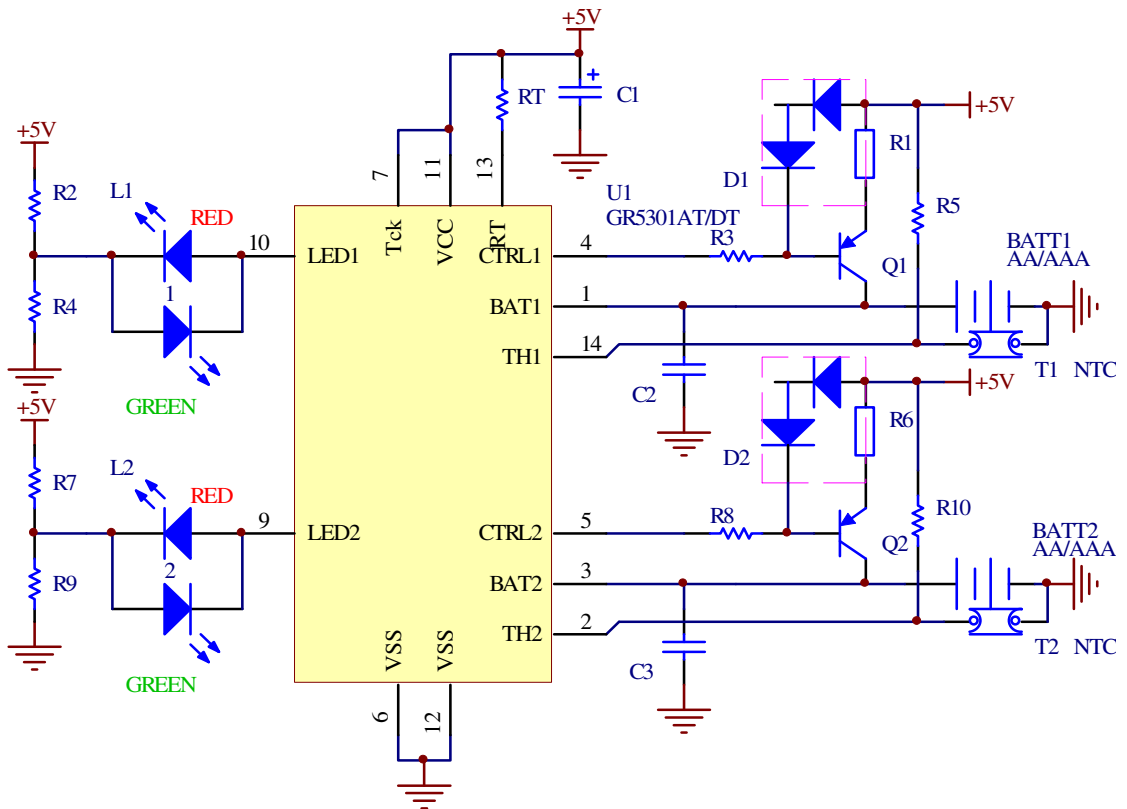

GR5301AS/DS

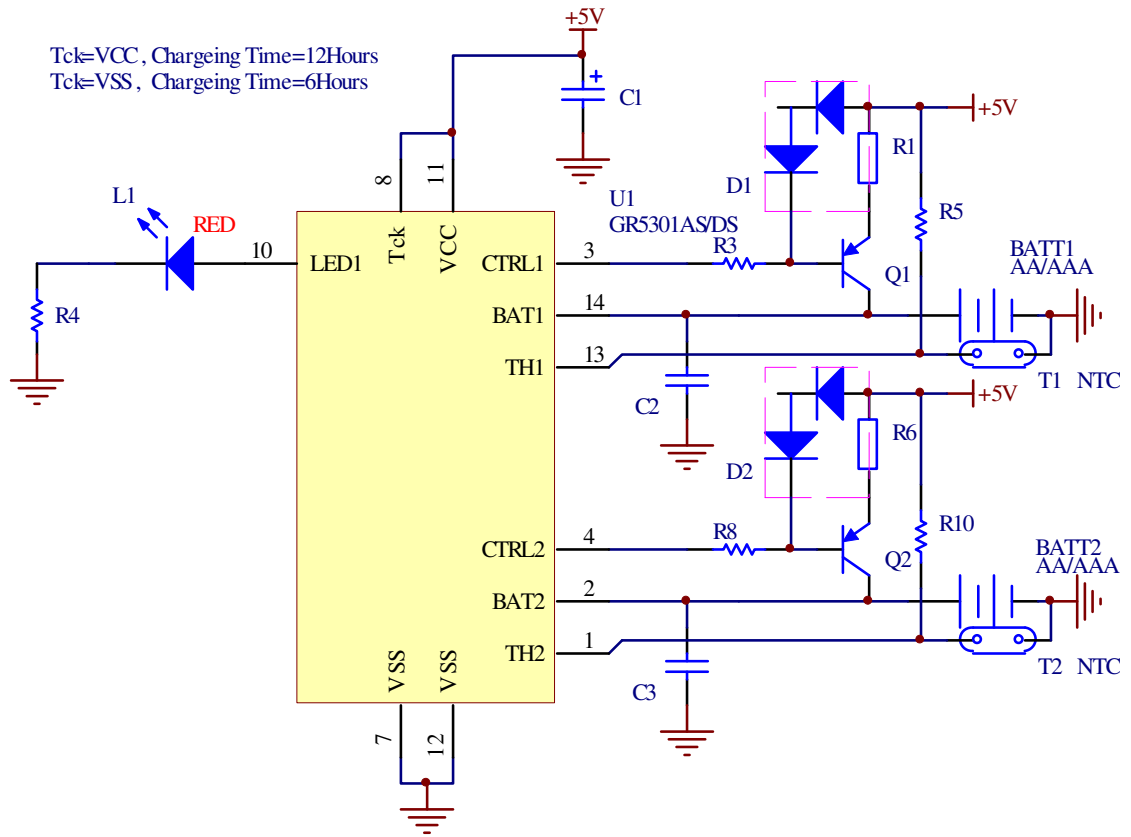

Package Information

SOP-14

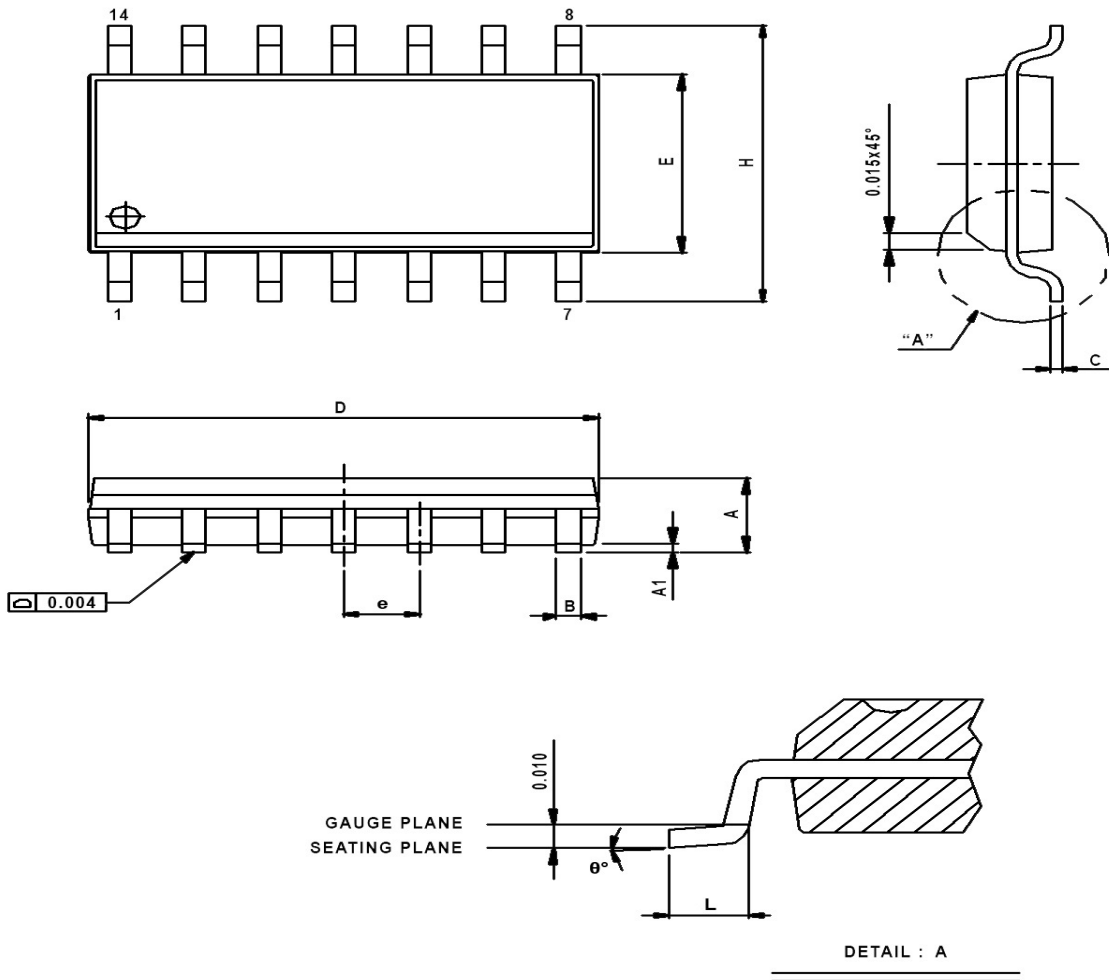

Symbols	MIN.	NOM.	MAX.
A	0.058	0.064	0.068
A1	0.004	-	0.010
B	0.013	0.016	0.020
C	0.0075	0.008	0.0098
D	0.336	0.341	0.344
E	0.150	0.154	0.157
e	-	0.050	-
H	0.228	0.236	0.244
L	0.015	0.025	0.050
θ°	0	-	8

UNIT: INCH

Carrier Tape & Reel Dimensions

SOP-14

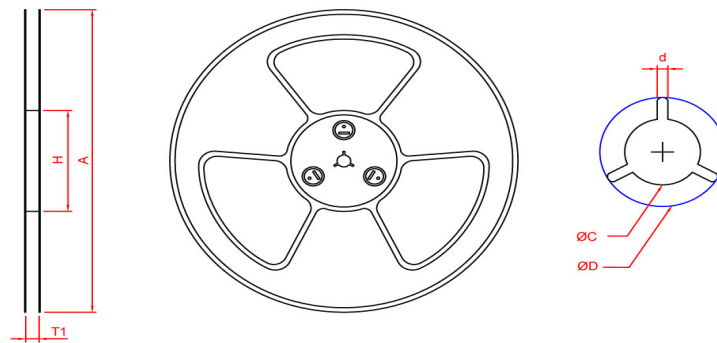
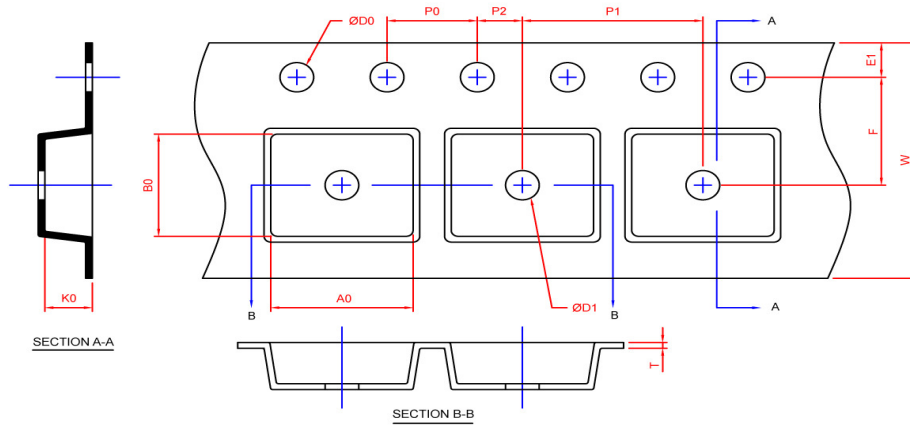

Application	A	H	T1	C	d	D	W	E1	F
SOP-14	330.0±2.0	100 REF	1.4	13.0 +0.5 -0.2	2.0±0.5	16.5 REF	16.0±0.2	1.75±0.1	7.5±0.1
	P0	P1	P2	D0	D1	T	A0	B0	K0
	4.0±0.1	8.0±0.1	2.0±0.1	1.5+0.10 -0.00	1.5 MIN.	0.3±0.05	6.5±0.1	9.5±0.1	2.1±0.1

(mm)

Application	Devices Per Reel
SOP-14	2500

Greenergy OPTO, Inc. reserves the right to make corrections, modifications, enhancements, improvements, and other changes to its products and services at any time and to discontinue any product or service without notice. Customers should obtain the latest relevant information before placing orders and should verify that such information is current and complete.